

### 1、设计特点 DESIGN CHARACTERISTICS

主要的设计特点如下:

- 1) 全部采用低碳合金钢渗碳处理
- 2) 齿轮及齿轮轴精度高
- 3) 体积小、扭矩大

The characteristics are as follows:

- 1) Uses low-carbon alloyed steel cementation processing completely
- 2) The gear and the gear shaft precision is high
- 3) The volume small, the torque is big

(A1)

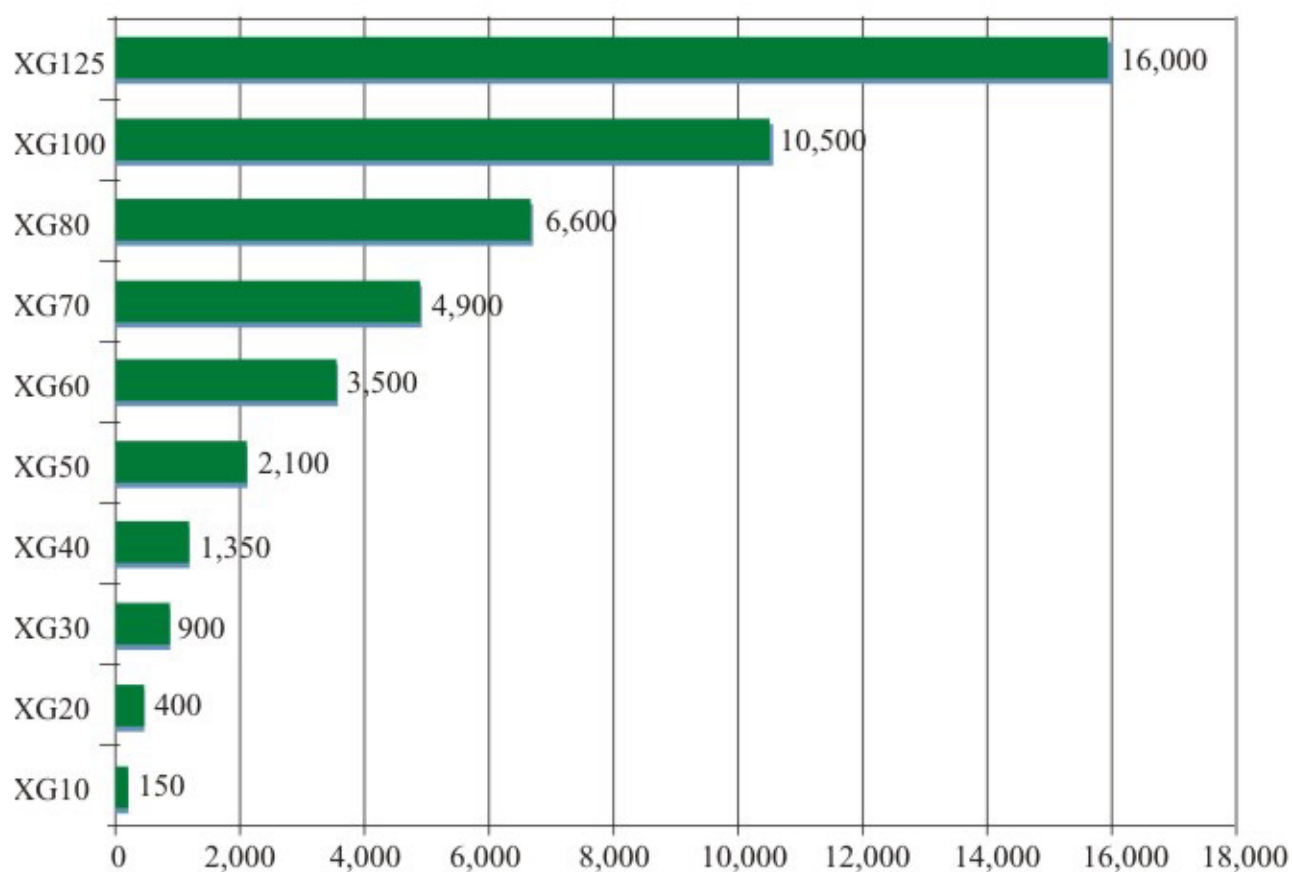

$Mn_2$ [Nm]- $n_1=900\text{min}^{-1}$



## 2、功率 POWER

### 额定功率

$P_{n1}[\text{KW}]$

在齿轮箱选择图表中，功率是指在使用系数  $f_s=1$  的情况下，作用于输入轴上的，与输入转速有关。

### Rated power

$P_{n1}[\text{KW}]$

The power is the one based on input shaft, it also relate to the speed under the situation of service factor  $f_s=1$ .

## 3、使用系数 Service factor

该要素表示齿轮箱的使用系数，考虑到不可避免的误差及正常操作条件中的负荷不同，不论使用系数是怎样的值，我们都希望提醒您：在一些应用中，如零部件的装配，齿轮箱的故障，都有可能对导致齿轮箱的损坏。假如你有疑问，请与我们技术中心联系。

Service factor is the one describing reducer service duty, considering unavoidable approximation and the difference of daily operating condition, involve fitting of parts, failure of the reducer all lead to the injure of the gearbox. If you have any question, please contact our technical service.

(A2)

每小时启动次数 Starts per hour	负荷 Duty	每天操作小时数 Daily operating hours			
		$H \leq 0.5$	$0.5 < h \leq 2$	$2 < h \leq 10$	$10 < h \leq 24$
$Z < 10$	均布荷载 Uniform loading	0.8	0.9	1.0	1.25
	中度瞬间荷载 moderate shock loading	0.9	1.0	1.25	1.5
	重度瞬间荷载 heavy shock loading	1.0	1.25	1.5	1.75
$Z \geq 10$	均布荷载 Uniform loading	0.9	1.0	1.25	1.5
	中度瞬间荷载 moderate shock loading	1.0	1.25	1.5	1.75
	重度瞬间荷载 heavy shock loading	1.25	1.5	1.75	2.0

上面列出的值在下列情况下必须乘以1.2

- 换向操作
- 瞬时冲击负荷

Values listed above must be multiplied by 1.2 in case of:

- Reversing operation
- Shock loading applying instantaneously

#### 4、扭 矩 TORQUE

**许用扭矩**
 **$M_{n2}[\text{Nm}]$** 

齿轮箱在使用系数 $f_s=1$ 的情况下，通过输出轴所传递的扭矩，许用扭矩与转速有关。

**工作扭矩**
 **$M_{r2}[\text{Nm}]$** 

扭矩要求是基于应用要求的。

它必须是相同于或小于研究的齿轮箱的许用扭矩  $M_{n2}$ 。

**输出扭矩**
 **$M_{c2}[\text{Nm}]$** 

输出扭矩值在选择齿轮箱时将使用到。

在考虑工作扭矩 $M_{r2}$ 和使用系数 $f_s$ 后可按照下列公式计算出来：

**Rated torque**
 **$M_{n2}[\text{Nm}]$** 

Rated torque is the one through the output shaft, and also relate to the speed. It is used under the situation of service factor  $f_s=1$

**Required torque**
 **$M_{r2}[\text{Nm}]$** 

Required torque is the one through the a ctual application requirement. It must be equal too less than the rated torque  $M_{n2}$

**Cal culated torque**
 **$M_{c2}[\text{Nm}]$** 

Cal culated torque is the one used in selecting the gearbox. We can have the value as per the equation after considering both required torque  $M_{r2}$  and service factor  $f_s$

$$M_{c2} = M_{r2} \cdot f_s < M_{n2} \quad (1)$$

#### 5、转 速 SPEED

**输入转速**
 **$n_1[\text{min}^{-1}]$** 

该速度是和选择的电机有关的按照目录上的值是指工业中常见的单速或双速马达的速度。

假如齿轮箱是通过外部电机驱动的，我们建议在1400rpm或以下的速度下操作齿轮箱，这样可以优化操作条件和使用寿命。更高的输入转速是允许的，但是这样的话，许用扭矩 $M_{n2}$ 将受到影响。

详情请咨询温州三联代表。

**输出转速**
 **$n_2[\text{min}^{-1}]$** 

输出转速值 $n_2$ 是通过输入转速 $n_1$ 和齿轮数比 $i$ 之间的关系，按照下列公式计算的：

**Input speed**
 **$n_1[\text{min}^{-1}]$** 

The speed is the one used in industry driven by either single or double speed motor. It is based on the selected motor.

If the gearbox is driven by outer motor, we suggest the speed under 1400rpm or even over which will optimize operating conditions and lifetime, Though the higher input shaft is permitted, the rated torque  $M_{n2}$  will be affected.

Please contact HENGFENGTAI representative for more information.

**Output speed**
 **$N_2[\text{min}^{-1}]$** 

Output speed  $n_2$  is the one calculated by the following equation through the input speed  $n_1$  and the gear radion  $i$ .

$$n_2 = \frac{n_1}{i} \quad (2)$$

### 6、选型 SELECTION

A. 决定使用系数  $f_2$

A) Determine the service factor  $f_2$

B. 根据已知的  $M_{r2}$  算出输出扭矩, 扭矩计算公式如下:

b) Calculate the output torque  $M_{r2}$  according to the rated torque, the equation as:

$$M_{c2} = M_{r2} \cdot f_s \quad (3)$$

C. 齿轮速比是按照客户要求输出转速  $n_2$  和输入转速  $n_1$  计算出来的:

C) Calculate ratio according to the output speed  $N_2$  and input speed  $N_1$ :

$$i = \frac{n_1}{n_2} \quad (4)$$

如果  $M_{c2}$  和  $i$  是已知的话, 在选型表中根据合适的输入转速, 找出与减速比  $i$  最接近的减速机型号, 并同是满足许用扭矩值  $M_{n2}$  如下:

If you have known the  $M_{c2}$  and  $i$ , select the suitable input speed in the chart, and find out which is the closest reducer model with ratio  $i$ , at same time satisfy the rated torque  $M_{n2}$  as following:

$$M_{n2} \geq M_{c2} \quad (5)$$

### 7、安装 INSTALLATION

以下安装指示必须遵守

A Make sure the correct installation of gear boxes to avoid vibrations. Install hydraulic coupling, clutched torque limiters, etc if used in shocked or over-loaded situation.

A. 确保齿轮箱正确的安装, 以防止松动。假如必须在超负荷或有震动的场合使用, 请安装液压偶合器, 扭矩限制器等。

B Before the operation of gearbox, please make sure the connected equipments accord with the technical specification.

B. 在上漆之前, 零件加工面和油封外表面必须有保护措施, 以防止油漆干在橡胶上面破坏密封功能。

C The machine surface and the outer face of the oil seals must be protected before painting in order to keep the sealing faction.

C. 齿轮箱在投入使用之前, 应确保和齿轮箱连接的设备应符合相关的技术规定。

D Before the starting of machine makes sure the oil level conforms to the machine level, the viciousness of oil is suitable for gearbox. Detail in chart A4.

D. 在启动机器之前, 应确保油面符合齿轮箱的规定的装配位置, 油的黏度应适合齿轮箱的使用的。详见图表A4.

E For outdoor in stallation, we should take proper way to protect motors from ranfalls as well as sunshine.

E. 对于室外安装, 必须采用适当的措施来保护电机不受下雨或阳光曝晒的影响。

在装配之前, 各安装面必须保持干净, 并进行适当的处理以防止生锈。

All surfaces should keep clean before installation, and take proper method to prevent rusting.

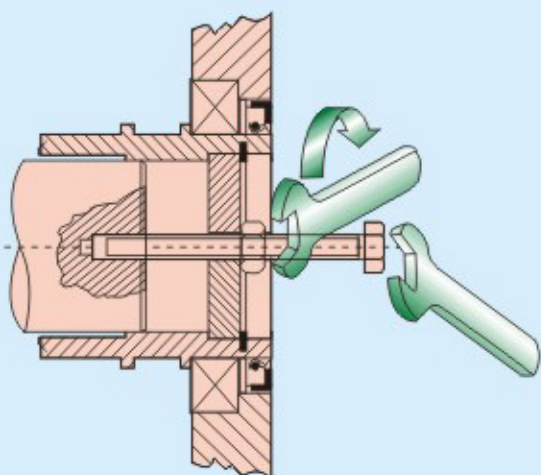
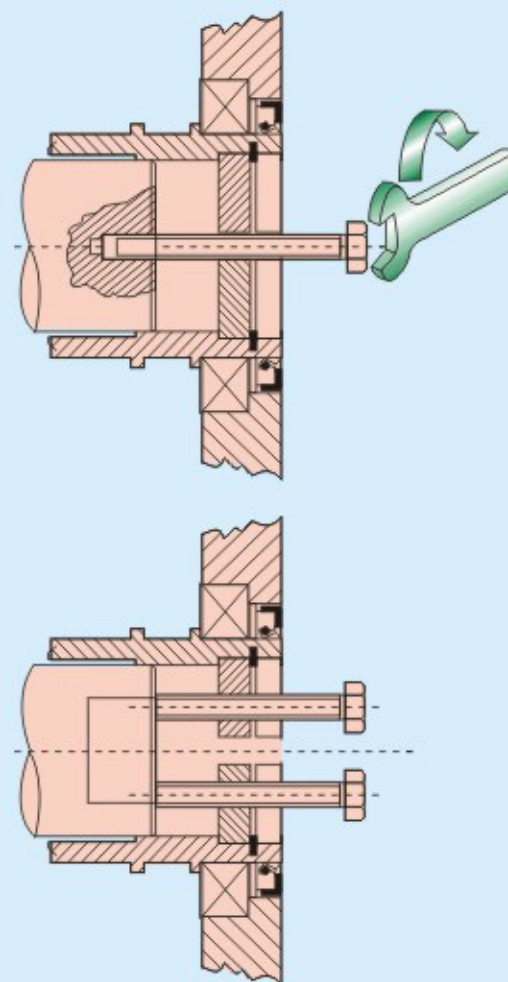
**安装齿轮箱**
**MOUNTING OF GEAR UNIT**

**拆卸齿轮箱**
**REMOVAL OF GEAR UNIT**

**8、核 查 VERIFICATION**
**径向负载**

确保应用于输入和输出轴的径向负载是在许用范围内的。

假如它们超出许用范围，在选用更大型号的减速机之前可先考虑设计特殊轴承结构。

如径向负荷不在轴伸的中间，应对其进行必要的修正，具体修正方法与我们技术中心联系。

**轴向负荷**

轴向负荷必须在许用径向负荷的20%以内。

假如特别的高出，或者是轴向和径向负荷的综合作用，请与我们技术中心联系。

**Radial loads**

Make sure the radial loads both in input shaft and output shaft is with in the permitted range.

If it surpasses the permitted range,we can choose to select special designed bearing structure before switching to alarger gear unit.

It must be adjusted if the radial loads are not in the middle of the shaft please contact our technical service to gain more in formation.

**Thrust loads**

Thrust loads must be found with in 20% of the radial loads.If exrtremely high,or a combination of radial and thrust loads,contact our technical service.

### 9、维护 MAINTENANCE

在操作满300小时后，应该进行第一次换油，用合适的清洁剂冲洗齿轮机构。

不要把矿物油和合成油混合使用。

定期检查油的水平面，并且按照下列表格中的时间间隔换油。

After the 300 hour of operation, please change the oil, and flush the gear unit with suitable detergents.

Don't mix the mineral oil and synthetic oil.

Please check the oil level in regular time, and change the oil according the following table.

( A3 )

油温 Oil temperature [ °C ]	换油间隔(小时) Oil change interval [ h ]	
	矿物油 Mineral oil	合成油 Synthetic oil
<65	8000	25000
65-80	4000	15000
80-95	2000	12500

### 10、油漆规格 PAINT SPECIFICATIONS

在齿轮箱上使用的油漆的规格必须从提供本机器的经销商或代理商处获得。

The paint specifications on gearbox must be obtained from the suppliers.

### 11、供货条件 CONDITIONS OF SUPPLY

齿轮机构是按照以下供应的

- A.按照订购时说明的安装和装配位置进行配置；
- B.按照制造商的说明进行了测试；
- C.在运输过程中，轴是用塑料封壳保护起来的；
- D.提供了吊耳（当适用的时候）。

Gearboxes are supplied as follows:

- A) Assembled the gearbox according to the installing and mounting position specified when ordering.
- B) Tested following the manufacturer specifications.
- C) During the transportation, shaft is protected with plastic seals.
- D) lifting lugs were supplied.

### 12、储存 STORAGE

按照下列指示来确保产品的正确的储存。

A.不要在室外储存，不要在曝露在外受到天气影响和温度很高的地方储存。

B.请在产品和地面之间放置纸板，木头或其它材料。齿轮箱不能直接和地面接触。

According to the following indications to make sure correct storage of products.

A) Don't store in somewhere exposed to be affected with weather and humidity.

B) Please put cardboard, wood or other material between the products and floor. The gearboxes aren't permitted to direct contact with floor.

C.假如需要储存很长时间，一些机器加工面例如法兰，轴和联轴器必须涂上适合的防锈的产油（MOBILARMA248或等同的产品）。

此外，齿轮箱的油位必须处于最高位并加满油。设备在重新投入使用之前，油量和类型都必须重新恢复。

C) For long-term storage, the surfaces of parts such as shafts, couplings and flanges must be coated with suitable oil to avoid rusting.

Another point is that gearbox must be placed the fill plug in the highest position and filled up with oil. (MOBILARMA 248 or Equivalent).

Before reusing the equipments, the oil quantity and type must be restored.

### 13、型号标识说明 DESIGNATION

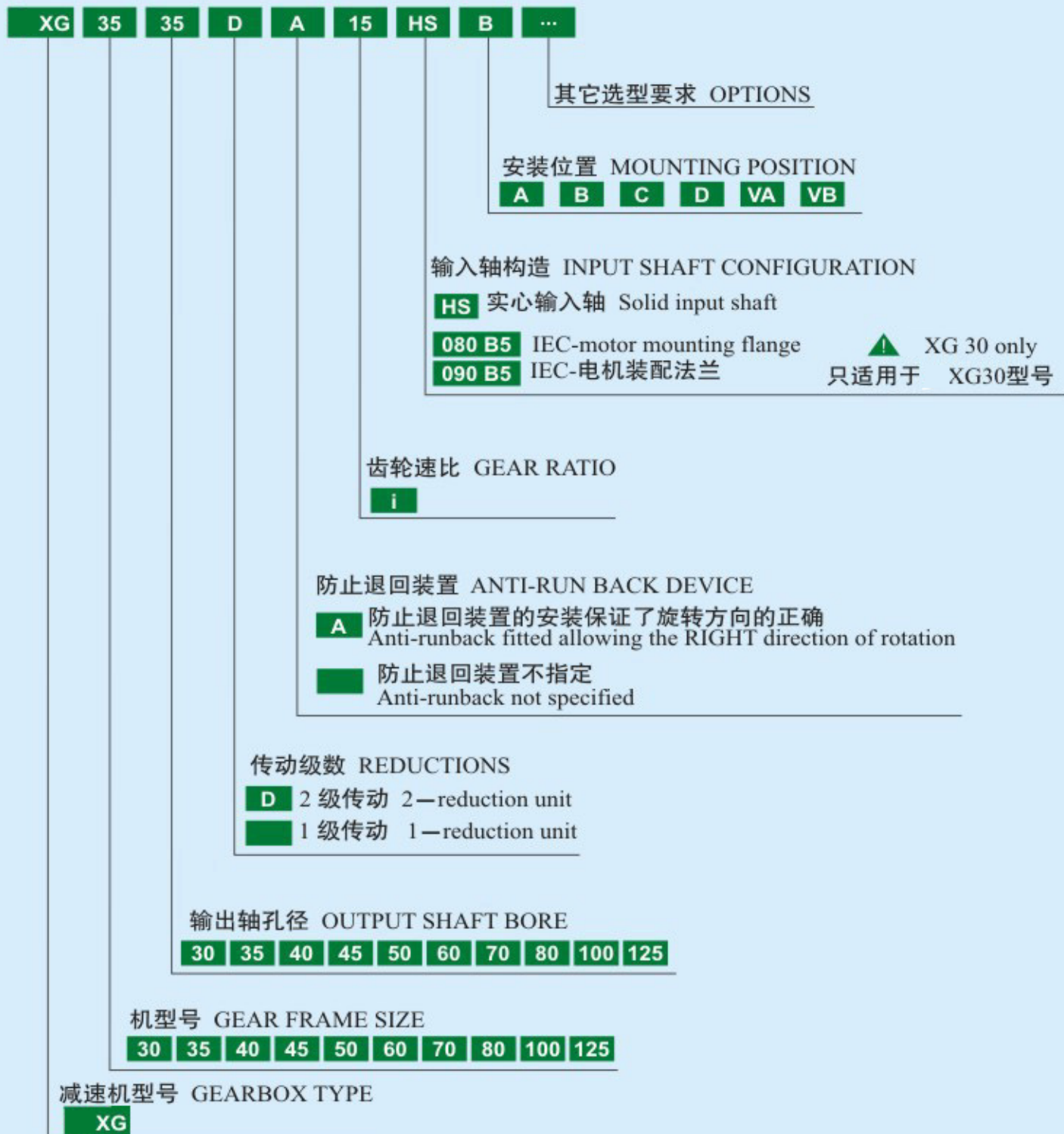

**齿轮箱其它选型要求 GEARBOX OPTIONS**
**LO**

齿轮箱，除非客户有特殊的要求，否则出厂时都不加油。  
油量根据订货时指定的安装方式来订。

**LO**

Gearboxes are not filled up with oil unless customers have special requirements.  
Oil quantity is based on the mounting position specified when ordering.

**PV**

VITON 橡胶油封。

**PV**

Oil seal in viton.

**AL**

规定了逆时针方向旋转。

**AL**

Specified opposite direction of rotation.

**14. 润滑 LUBRICATION**

温州三联齿轮箱的内部件是浸油的和飞溅润滑的。

下面的图表可以参考安装位置和相应的油塞，假如适用的话，和对应的润滑剂量。

油量的值是否已经正确的装油，可通过油镜的中心或提供的量油计来衡量。

在某些情况下有差异，偶尔不合格格，假如和在下图表中列出的油量不一样的则需要注意。

The interprets of Wenzhousanlian gearboxes are oil-soak and splash lubricated.

The following charts indicate the mounting position model and relevant oil plug.If applicable. Here is the corresponding lubricant quantity.

If the oil quantity is correct filling:it can be measured by the center of sight glass or supplied dipstick.

Maybe there are some misnomers and falling short of specification.Which are different from listed oil quantity must benoticed.

( A4 )

负载类型 Type of duty	XG 0°C-20°C		XG 20°C-40°C	
	矿物油 Mineral oil ISO VG	合成油 Synthetic oil ISO VG	矿物油 Mineral oil ISO VG	合成油 Synthetic oil ISO VG
轻型 Tight duty	150	150	220	220
中型 Medium duty	150	150	320	220
重型 Heavy duty	200	200	460	320

### 油量 ( I ) Oil quantity [I]

(A5)

XG30	XG35	XG40	XG45	XG50	XG60	XG70	XG80	XG100	XG125
	1.2	2.1	3.1	8.0	7.5	11	17	20	27
0.50	XG35_D	XG40_D	XG45_D	XG50_D	XG60_D	XG70_D	XG80_D	XG100_D	XG125_D
	1.1	1.8	3.6	7.3	10	14	11	18	27

油量只和装配位置A相对应 Quantities are only relevant to mounting position A.

### 15、安装方位 MOUNTING POSITIONS

	关键:	Key:
	透气塞	Filling/breather plug
	油镜/油标	Level plug
	油塞	Drain plug

#### XG30-125

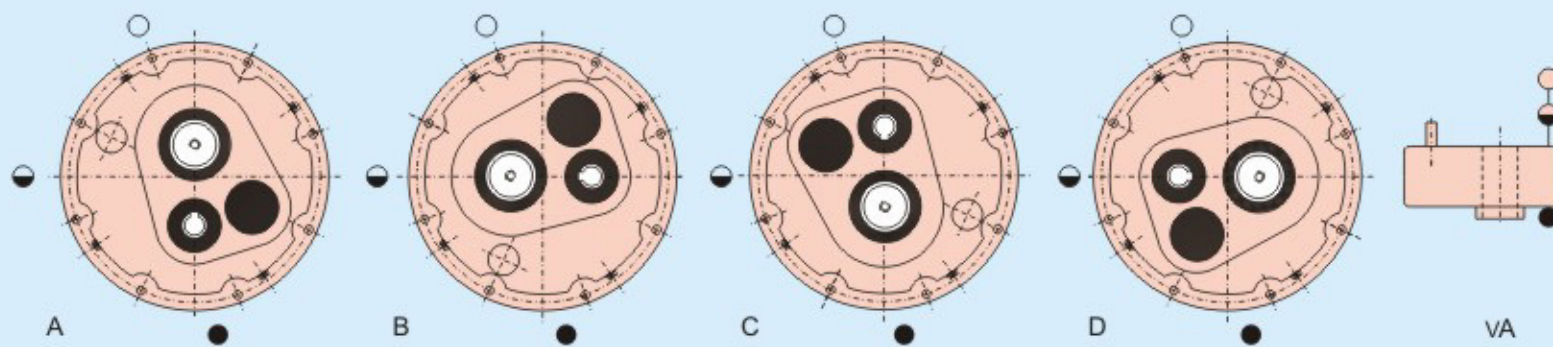

#### XG30D-125D

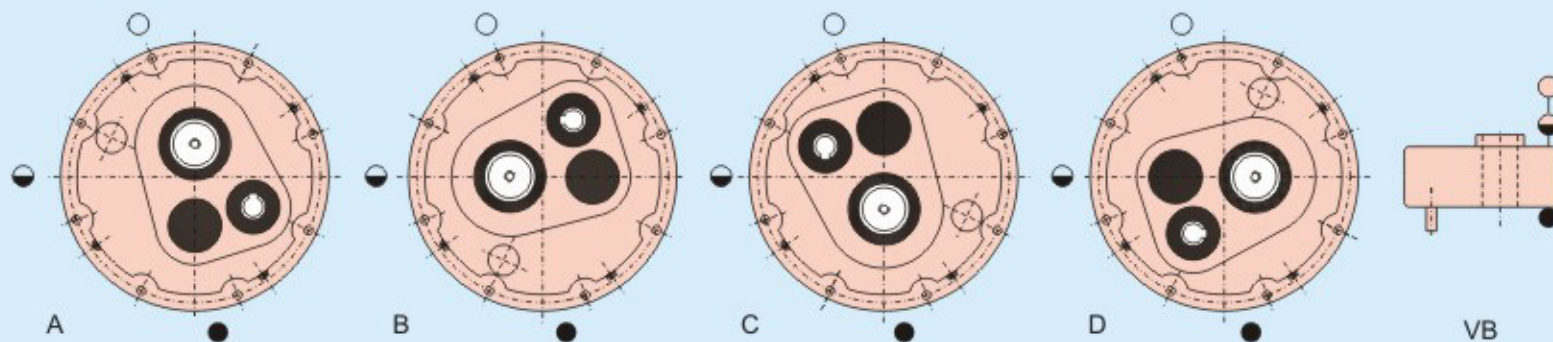

**16、悬挂负载 OVERHUNG LOADS**

通过键把外部传动递到输入轴和输出轴，在同一根轴上的垂直方向产生负载。

Pass the external transmissions to input & output shafts by the key, loads act apeak on the same shaft.

由此产生的负载须与轴承和轴的性能相匹配。理论上，轴负载 (  $R_{c1}$  ) 必须等于或低于轴的许用悬挂负载的计算值 (  $R_{n1}$  ) 悬挂负载能力可在选型表中查出。

Loading must be suitable with both the shaft and bearing capacity. Ideally, shaft loading (  $R_{c1}$  ) must be equal or lower than overhung load (  $R_{n1}$  ) for calculating. Overhung loads capacity can locate in the option chart. The loads generated from external tran smission can be approximate calculated by the following equation.

外部传动所产生的负载可近似地用以下公式算出。

The actual shaft loading and overhung loads should be satisfied the following equation.

$$R_{c1}[N] = \frac{2000 \cdot M_1[Nm] \cdot K_r}{d [mm]} \quad (6)$$

**在公式中 Where:**

$m_1$  [Nm]=输出扭矩

$M_1$ [Nm]=torque applied to shaft

$d$ [mm]=轴的直径

$d$ [mm]=pitch diameter of part keyed on to shaft

$K_r=1$  链传动

$K_r=1$  chain trasmission

$K_r=1.25$  齿轮传动

$K_r=1.25$  gear transmission

$K_r=1.5-2.0$  带传动

$K_r=1.5-2.0$  belt transmission

实际轴负载和悬挂负载应满足以下公式

Acomparision of shaft loading with catalogue OHL ratings should verify the following condition:

$$R_{c1} \leq R_{n1} \quad (7)$$

**17、减速机选型表 RATING CHARTS**
**许用输出扭矩(Nm)**

机型号 Model	XG30	XG35	XG40	XG45	XG50	XG60	XG70	XG80	XG100	XG125
许用转矩 Permitted torque	180Nm	420Nm	950Nm	1400Nm	2300Nm	3600Nm	5100Nm	7000Nm	11000Nm	17000Nm

**输入转速 n1=1400rpm**

公称传动比	精确传动比	输出转速	额定输出转速	额定输入功率	悬挂载荷	机型号
Nominal ratio iN	Exact ratio iex	Output speed n2[rpm]	Rated output torque Mn2[Nm]	Rated input power Pn1[KW]	Overhung loads Rn1[N]	Model
5	5	280	200	6.0	700	XG35 35
	5	280	480	14.4	1000	XG40 40 45
	5	280	850	26.0	1500	XG45 45 50 55
	5	280	1400	42.0	2250	50 XG50 55 60
	5	280	1900	57.0	3200	XG60 60 70
	5	280	2600	78.0	3700	XG70 70 85
	5	280	3700	111.0	4500	XG80 80 100
	5	280	5500	165.0	5500	XG100 100 125
	5	280	7500	226.0	6500	XG125 125 135
7	7.2	194	137	2.9	350	XG30 30
10	10	140	137	2.1	350	XG30 30
	10	140	300	4.6	500	XG35 35 D
	10	140	600	9.2	850	XG40 40 45 D
	10	140	1000	15.4	1150	45 XG45 50 D 55
	10	140	1750	27.0	1700	50 XG50 55 D 60
	10	140	3100	48.0	2600	XG60 60 70 D
	10	140	3800	59.0	3400	XG70 70 85 D
	10	140	5500	85.0	4200	XG80 80 100 D
	10	140	9000	139.0	5000	XG100 100 125 D
	10	140	12500	193.0	5500	XG125 125 135 D

**输入转速 n1=1400rpm**

公称传动比	精确传动比	输出转速	额定输出转速	额定输入功率	悬挂载荷	机型号
Nomimal ratio iN	Exact ratio iex	Output speed n2[rpm]	Rated output torque Mn2[Nm]	Rated input power Pn1[KW]	Overhung loads Rn1[N]	Model
12.5	12.7	110	137	1.6	350	XG35 30
	13.3	105	700	8.1	850	XG40 40 D 45
	12.2	115	1100	13.9	1150	XG45 45 D 50 55
	12	117	1800	23.0	1700	XG50 50 D 55 60
	12.2	115	3100	39.0	2600	XG60 60 D 70
	12.2	115	4000	51.0	3400	XG70 70 D 85
	12.5	112	5500	68.0	4200	XG80 80 D 100
	12.3	114	9000	113.0	5000	XG100 100 D 125
	12.3	114	12500	157.0	5500	XG125 125 D 135
15	15	93	350	3.6	500	XG35 35 D
	15	93	750	7.7	850	XG40 40 D 45
	15	93	1200	12.3	1150	XG45 45 D 50 55
	15	93	1900	19.5	1700	XG50 50 D 55 60
	15	93	3200	33.0	2600	XG60 60 D 70
	15	93	4400	45.0	3400	XG70 70 D 85
	15	93	6100	63.0	4200	XG80 80 D 100
	15	93	9500	98.0	5000	XG100 100 D 125
	15	93	12500	128.0	5500	XG125 125 D 135
20	19.5	72	380	3.0	500	XG35 35 D
	19.7	71	780	6.1	850	XG40 40 D 45
	19.7	71	1250	9.8	1150	XG45 45 D 50 55
	20.3	69	1950	14.8	1700	XG50 50 D 55 60

**输入转速 n1=1400rpm**

公称传动比	精确传动比	输出转速	额定输出转速	额定输入功率	悬挂载荷	机型号
Nomimal ratio iN	Exact ratio icx	Output speed n2[rpm]	Rated output torque Mn2[Nm]	Rated input power Pn1[KW]	Overhung loads Rn1[N]	Model
20	20.3	69	3250	25.0	2600	XG60 60 D 70
	20.3	69	4500	34.0	3400	XG70 70 D 85
	20.3	69	6100	46.0	4200	XG80 80 D 100
	20.3	69	9500	72.0	5000	XG100 100 D 125
	20.3	69	14000	106.0	5500	XG125 125 D 135
25	25	56	400	2.5	500	XG35 35 D
	25	56	800	4.9	850	XG40 40 D 45
	25	56	1300	8.0	1150	XG45 45 D 50
	25	56	2000	12.3	1700	XG50 50 D 55
	25	56	3300	20.0	2600	XG60 60 D 70
	25	56	4600	28.0	3400	XG70 70 D 85
	25	56	6300	31.0	4200	XG80 80 D 100
	25	56	9800	60.0	5000	XG100 100 D 125
	25	56	15000	92.0	5500	XG125 125 D 135
31	33.2	42	800	3.7	850	XG40 40 D 45
	30.4	46	1300	6.6	1150	XG45 45 D 50
	30	47	2000	10.3	1700	XG50 50 D 55
	30.4	46	3300	16.7	2600	XG60 60 D 70
	30.4	46	4600	23.0	3400	XG70 70 D 85
	31.1	45	6300	31.0	4200	XG80 80 D 100
	30.8	45	9800	49.0	5000	XG100 100 D 125
	30.8	45	15000	75.0	5500	XG125 125 D 135

**输入转速 n1=900rpm**

公称传动比	精确传动比	输出转速	额定输出转速	额定输入功率	悬挂载荷	机型号
Nomimal ratio iN	Exact ratio icx	Output speed n2[rpm]	Rated output torque Mn2[Nm]	Rated input power Pn1[KW]	Overhung loads Rn1[N]	Model
5	5	180	250	4.8	800	XG35 35
	5	180	550	10.6	1200	XG40 40 45
	5	180	950	18.4	1700	XG45 45 50 55
	5	180	1700	33.0	2500	XG50 50 55 60
	5	180	2100	41.0	3600	XG60 60 70
	5	180	3000	58.0	4200	XG70 70 85
	5	180	4200	81.0	5100	XG80 80 100
	5	180	6200	120.0	6200	XG100 100 125
	5	180	8000	155.0	7300	XG125 125 135
7	7.2	125	150	2.0	400	XG30 30
10	10	90	150	1.4	400	XG30 30
	10	90	350	3.5	600	XG35 35 D
	10	90	750	7.4	950	XG40 40 45 D
	10	90	1200	11.9	1300	XG45 45 50 D 55
	10	90	1900	18.8	1900	XG50 50 55 D 60
	10	90	3200	32.0	2900	XG60 60 70 D
	10	90	4400	44.0	3800	XG70 70 85 D
	10	90	6100	60.0	4700	XG80 80 100 D
	10	90	9500	94.0	5600	XG100 100 125 D
	10	90	14000	139.0	6200	XG125 125 135 D
12.5	12.7	71	150	1.1	400	XG30 30 D
	13.3	68	780	5.8	950	XG40 40 45 D
	12.2	74	1200	9.7	1300	XG45 45 50 D
	12	75	1900	15.7	1900	XG50 50 55 D 60

**输入转速 n1=900rpm**

公称传动比	精确传动比	输出转速	额定输出转速	额定输入功率	悬挂载荷	机型号
Nominal ratio iN	Exact ratio iex	Output speed n2[rpm]	Rated output torque Mn2[Nm]	Rated input power Pn1[KW]	Overhung loads Rn1[N]	Model
12.5	12.2	74	3200	26.0	2900	XG60 60 D 70
	12.2	74	4400	36.0	3800	XG70 70 D 85
	12.5	72	6100	48.0	4700	XG80 80 D 100
	12.3	73	9500	77.0	5600	XG100 100 D 125
	12.3	73	14000	113.0	6200	XG125 125 D 135
15	15	60	400	2.6	600	XG35 35 D
	15	60	800	5.3	950	XG40 40 D 45
	15	60	1250	8.3	1300	XG45 45 D 50
	15	60	1950	12.9	1900	XG50 50 D 55
	15	60	3300	22.0	2900	XG60 60 D 70
	15	60	4500	30.0	3800	XG70 70 D 85
	15	60	6300	42.0	4700	XG80 80 D 100
	15	60	10000	66.0	5600	XG100 100 D 125
	15	60	15000	99.0	6200	XG125 125 D 135
20	19.5	46	400	2.0	600	XG35 35 D
	19.7	46	800	4.0	950	XG40 40 D 45
	19.7	46	1300	6.5	1300	XG45 45 D 50
	20.3	44	2000	9.8	1900	XG50 50 D 55
	20.3	44	3400	16.6	2900	XG60 60 D 70
	20.3	44	4600	22.0	3800	XG70 70 D 85
	20.3	44	6300	31.0	4700	XG80 80 D 100
	20.3	44	10000	49.0	5600	XG100 100 D 125
	20.3	44	15000	73.0	6200	XG125 125 D 135

**输入转速 n1=900rpm**

公称传动比	精确传动比	输出转速	额定输出转速	额定输入功率	悬挂载荷	机型号
Nomimal ratio iN	Exact ratio icx	Output speed n2[rpm]	Rated output torque Mn2[Nm]	Rated input power Pn1[KW]	Overhung loads Rn1[N]	Model
25	25	36	400	1.6	600	XG35 35 D
	25	36	850	3.4	950	XG40 40 D 45 D
	25	36	1350	5.4	1300	XG45 45 D 50 D 55 D
	25	36	2100	8.3	1900	XG50 50 D 55 D 60 D
	25	36	2500	13.9	2900	XG60 60 D 70 D
	25	36	4900	19.4	3800	XG70 70 D 85 D
	25	36	6600	26.0	4700	XG80 80 D 100 D
	25	36	10500	42.0	5600	XG100 100 D 125 D
	25	36	16000	63.0	6200	XG125 125 D 135 D
31	33.2	27.1	900	2.7	950	XG40 40 D 45 D
	30.4	29.6	1350	4.4	1300	XG45 45 D 50 D 55 D
	30	30	2100	6.9	1900	XG50 50 D 55 D 60 D
	30.4	29.6	3500	11.4	2900	XG60 60 D 70 D
	30.4	29.6	4900	16.0	3800	XG70 70 D 85 D
	31.3	28.8	6600	21.0	4700	XG80 80 D 100 D
	30.8	29.2	10500	34.0	5600	XG100 100 D 125 D
	30.8	29.2	16000	51.0	6200	XG125 125 D 135 D

**输入转速 n1=500rpm**

公称传动比	精确传动比	输出转速	额定输出转速	额定输入功率	悬挂载荷	机型号
Nomimal ratio iN	Exact ratio icx	Output speed n2[rpm]	Rated output torque Mn2[Nm]	Rated input power Pn1[KW]	Overhung loads Rn1[N]	Model
5	5	100	350	3.8	1000	XG35 35
	5	100	700	7.5	1500	XG40 40 45
	5	100	1100	11.8	2150	XG45 45 50 55

**输入转速 n1=500rpm**

公称传动比	精确传动比	输出转速	额定输出转速	额定输入功率	悬挂载荷	机型号
Nominal ratio iN	Exact ratio iex	Output speed n2[rpm]	Rated output torque Mn2[Nm]	Rated input power Pn1[KW]	Overhung loads	Model
5	5	100	1900	20.0	3100	XG50 50 55 60
	5	100	2900	32.0	4500	XG60 60 70
	5	100	4000	43.0	5200	XG70 70 85
	5	100	5000	54.0	6400	XG80 80 100
	5	100	7000	75.0	7900	XG100 100 125
	5	100	10000	107.0	9200	XG125 125 135
7	7.2	69	180	1.3	500	XG30 30
10	10	50	180	1.0	500	XG30 30
	10	50	400	2.2	750	XG35 35 D
	10	50	800	4.4	1200	XG40 40 D 45
	10	50	1300	7.2	1650	XG45 45 50 D 55
	10	50	2000	11.0	2400	XG50 50 D 55 60
	10	50	3300	18.2	3600	XG60 60 D 70
	10	50	4500	25.0	4750	XG70 70 D 85
	10	50	6300	35.0	5900	XG80 80 D 100
	10	50	10000	55.0	6800	XG100 100 D 125
	10	50	15000	83.0	7700	XG125 125 D 135
12.5	12.7	39	180	0.8	500	XG30 30
	13.3	38	820	3.4	1200	XG40 40 D 45
	12.2	41	1300	5.9	1650	XG45 45 50 D 55
	12	42	2000	9.2	2400	XG50 50 D 55 60
	12.2	41	3300	14.9	3600	XG60 60 D 70
	12.2	40	4500	20.0	4750	XG70 70 D 85

**输入转速 n1=500rpm**

公称传动比	精确传动比	输出转速	额定输出转速	额定输入功率	悬挂载荷	机型号
Nominal ratio iN	Exact ratio iex	Output speed n2[rpm]	Rated output torque Mn2[Nm]	Rated input power Pn1[KW]	Overhung loads	Model
12.5	12.5	40	6300	35.0	5900	XG80 80 D 100
	12.3	41	10000	45.0	6800	XG100 100 D 125
	12.3	41	15000	67.0	7700	XG125 125 D 135
15	15	33	400	1.5	750	XG35 35 D
	15	33	850	3.1	1200	XG40 40 D 45
	15	33	1300	4.8	1650	XG45 45 D 50
	15	33	2100	7.7	2400	XG50 50 D 55
	15	33	3550	13.0	3600	XG60 60 D 70
	15	33	4900	18.0	4750	XG70 70 D 85
	15	33	6600	24.0	5900	XG80 80 D 100
	15	33	10500	39.0	6800	XG100 100 D 125
	15	33	16000	59.0	7700	XG125 125 D 135
20	19.5	25.6	400	1.1	750	XG35 35 D
	19.7	25.4	850	2.4	1200	XG40 40 D 45
	19.7	25.4	1350	3.8	1650	XG45 45 D 50
	20.3	24.6	2100	5.7	2400	XG50 50 D 55
	20.3	24.6	3550	9.6	3600	XG60 60 D 70
	20.3	24.6	5000	13.6	4750	XG70 70 D 85
	20.3	24.6	6600	17.9	5900	XG80 80 D 100
	20.3	24.6	10500	28.0	6800	XG100 100 D 125
	20.3	24.6	16000	43.0	7700	XG125 125 D 135
25	25	20	420	0.92	750	XG35 35 D
	25	20	900	2.0	1200	XG40 40 D 45
	25	20	1400	3.1	1650	XG45 45 D 50

### 输入转速 n1=500rpm

公称传动比	精确传动比	输出转速	额定输出转速	额定输入功率	悬挂载荷	机型号
Nominal ratio iN	Exact ratio icx	Output speed n2[rpm]	Rated output torque Mn2[Nm]	Rated input power Pn1[KW]	Overhung loads	Model
25	25	20	2300	5.1	2400	XG50 50 D 55 D 60 D
	25	20	3600	7.9	3600	XG60 60 D 70 D
	25	20	5100	11.2	4750	XG70 70 D 85 D
	25	20	7000	15.4	5900	XG80 80 D 100 D
	25	20	11000	24.0	6800	XG100 100 D 125 D
	25	20	17000	37.0	7700	XG125 125 D 135 D
31	33.2	15.1	950	1.6	1200	XG40 40 D 45 D
	30.4	16.4	1400	2.5	1650	XG45 45 D 50 D 55 D
	30	16.7	2300	4.2	2400	XG50 50 D 55 D 60 D
	30.4	16.4	3600	6.5	3600	XG60 60 D 70 D
	30.4	16.4	5100	9.2	4750	XG70 70 D 85 D
	31.3	16	7000	12.3	5900	XG80 80 D 100 D
	30.8	16.2	11000	19.7	6800	XG100 100 D 125 D
	30.8	16.2	17000	30.0	7700	XG125 125 D 135 D



### 18、空心轴的尺寸 Hollow Shaft Dimensions

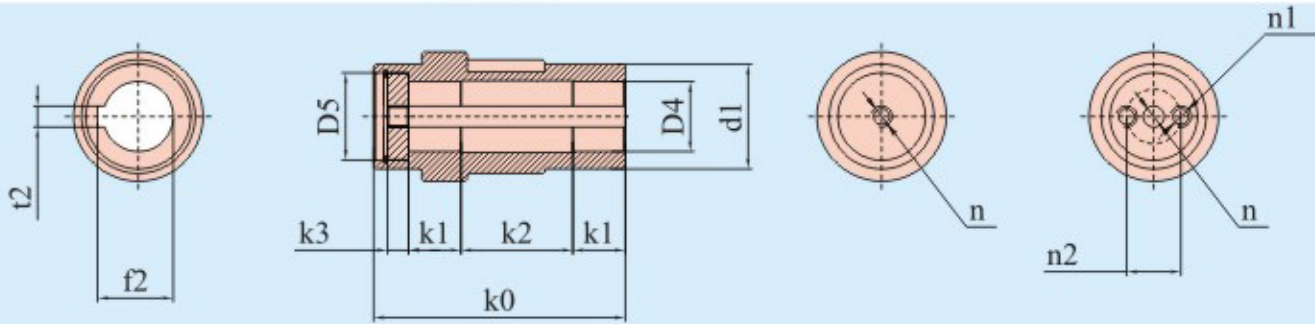

型号 Model	尺寸 Dimension											
	d1	D4	D5	k0	k1	k2	k3	f2	t2	n	n1	n2
XG35	50	35	42	124	30	46	10	38.3	10	M10		
XG40	40	60	40	144	30	64	12	43.3	12	M12		
	45		45					50	47.3		14	
XG45	45	75	45	162	35	70	14	48.8	14	M16		
	50		50					60	53.8		14	
	55		55					65	59.3		16	
XG50	50	85	50	182	40	80	14	53.8	14	M16		
	55		55					65	59.3		16	
	60		60					70	64.4		18	17
XG60	60	100	60	199	45	85	14	64.4	18	17	M12	42
	70		70				85	16	74.9	20	22	M16
XG70	70	120	70	223	50	93	16	74.9	20	22	M16	50
	85		85				100	18	90.4			22
XG80	80	140	80	249	55	109	18	85.4	22	22	M16	60
	100		100				120	107	20			106.4
XG100	100	160	100	288.5	60	136.5	20	106.4	28	26	M20	80
	125		125					145	132.4			32
XG125	125	170	125	304	60	137	20	132.4	32	26	M20	100
	135		135					150	143.4			36

### XG30 的外形尺寸 XG 30 Dimensions

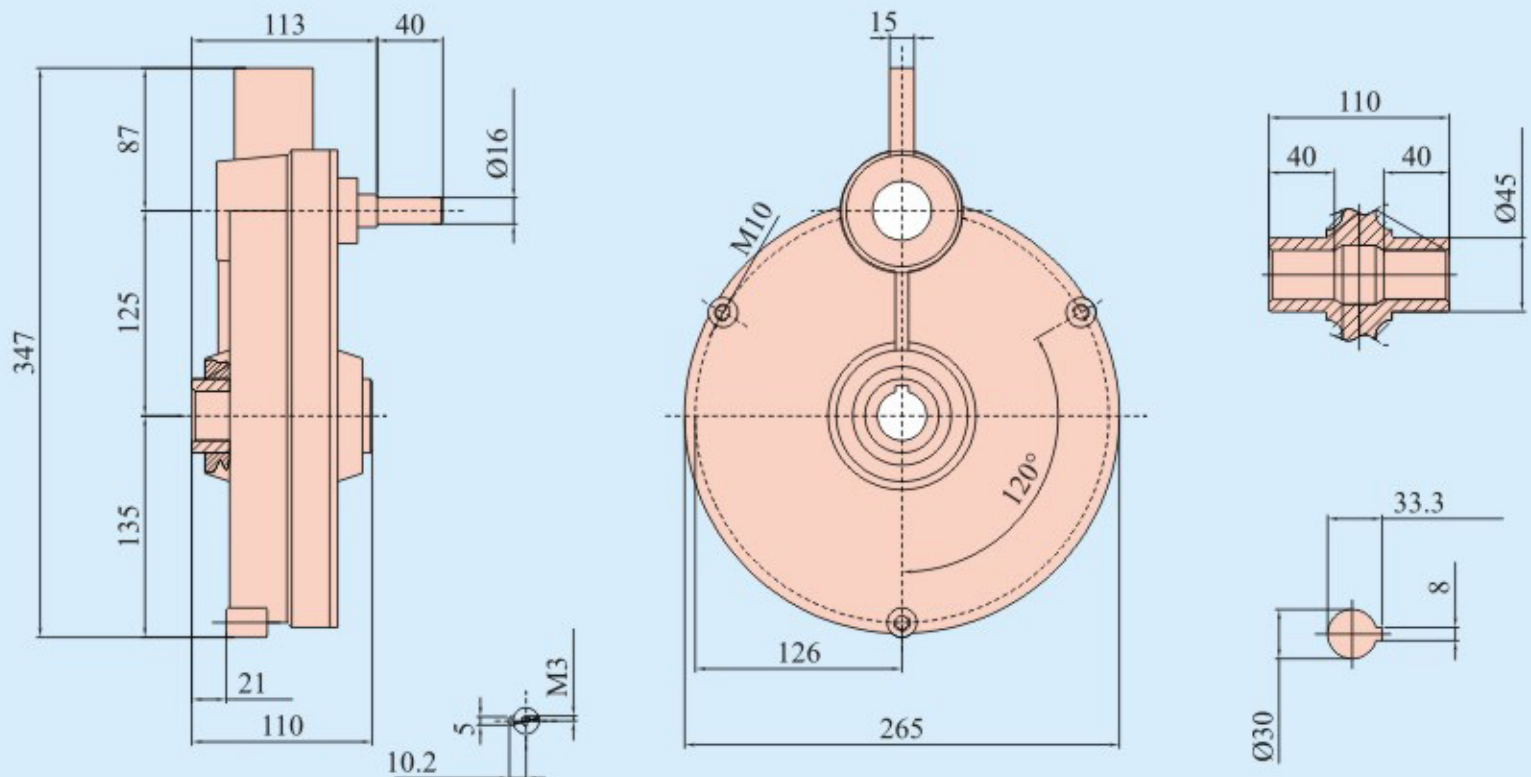

XG35- XG125 的外形尺寸

XG35- XG125 Dimensions

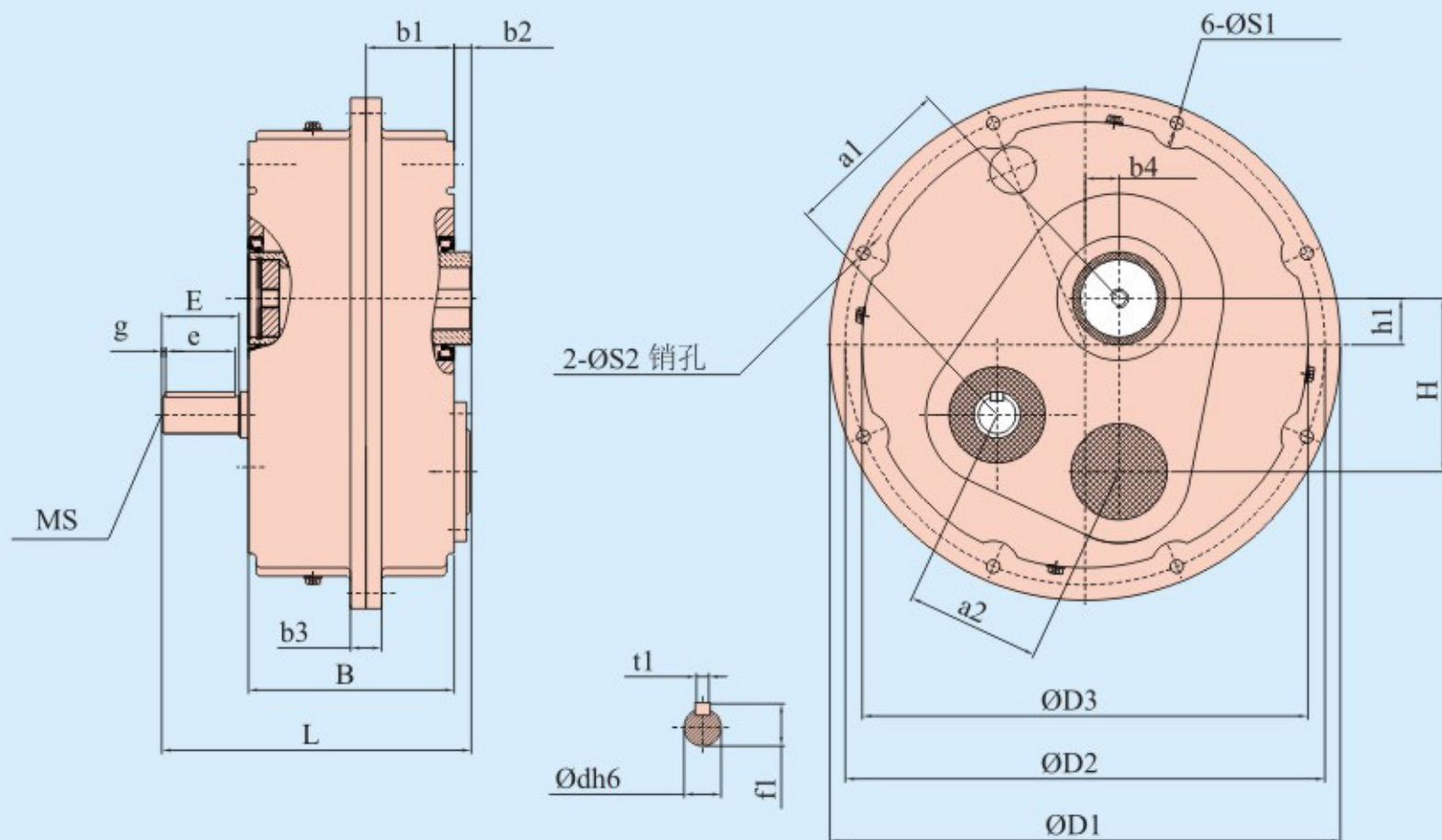

型号 Model	尺寸 Dimenstons																					重量 (kg)		
	a1	a2	H	h1	B	b1	b2	b3	b4	D1	D2	D3	d	E	e	g	f1	t1	S	s1	s2		L	
XG35	79	59	83	23	112	44	12	20	21	262	246	230	19	40	35	2.5	21.5	6	6	8.5	8	166	18	
XG35D																							20	
XG40	109	75	112	30	133	57	11	20	22	330	310	288	24	50	45	2.5	27	8	8	8.5	8	200	29	
XG40D																							31	
XG45	120	91	123	34	147	62	15	20	33	364	344	319	28	60	50	5	31	8	10	9	8	224	37	
XG45D																							41	
XG 50	140	117	143	40	167	66	15	25	46	435	410	384	38	80	70	5	42	10	12	11	10	270	58	
XG 50D																							62	
XG 60	162	130	174	47	184	73	15	28	48	500	468	438	42	110	100	5	45	12	12	13	12	318.5	88	
XG 60D													38	80	70		42	10					285	102
XG 70	182	139	188	52	205	84	18	28	53	550	520	474	48	110	100	5	51.5	14	16	13	12	338	115	
XG 70D													42				45	12	12				129	
XG 80	202	152	207	58	228	94	21	32	58	597	570	544	48	110	100	5	51.5	14	16	13	12	365	155	
XG80D																							170	
XG100	239	180	255	70	258.5	108	30	40	60	710	675	642	55	110	100	5	59	16	16	17	16	403.5	265	
XG100D													48				51.5	14					450	285
XG125	290	208	294	80	270	110	34	45	70	850	805	770	60	140	130	5	64	18	16	17	16	420	350	
XG125D													55	110	100		59	16					435	

### Accessory Dimensions

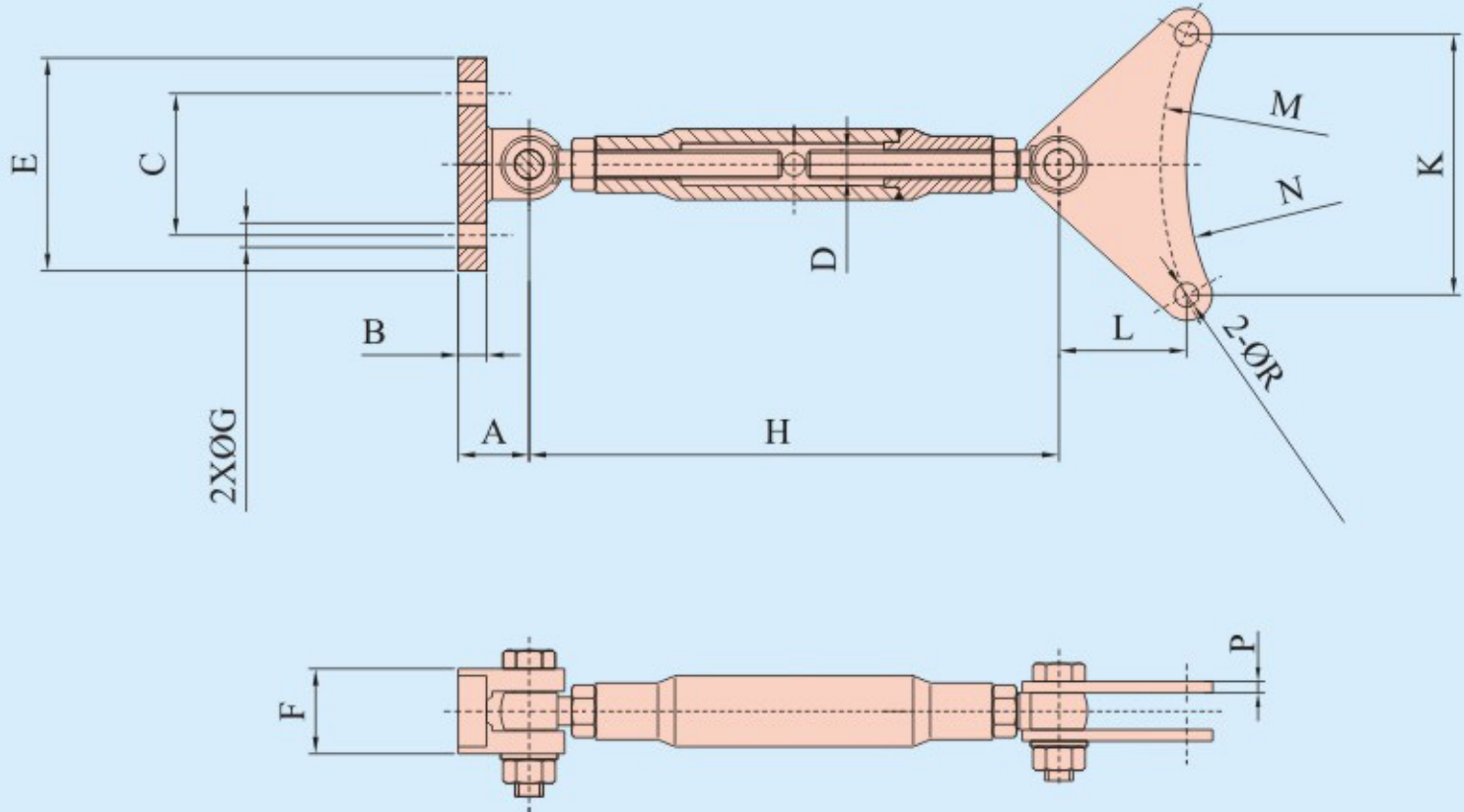

型号 Model	尺寸 Dimensions														
	A	B	C	D	E	F	G	H min max		K	L	M	N	R	P
XG35 35	25	10	50	M10	75	25	8.5	200	300	94.1	45	123	115	8.5	4
XG40 40 45	35	16	70	M12	105	35	10.5	210	310	118.6	51	155	147	8.5	4
XG45 45 50 55	35	16	70	M12	105	35	10.5	210	310	132	57	172	168	10.5	5
XG50 50 55 60	40	18	75	M14	115	40	12.5	240	360	157	70	205	198	10.5	5
XG60 60 70	40	18	75	M14	115	40	12.5	240	360	179	84	234	225	12.5	5
XG70 70 85	45	20	85	M16	135	50	14.5	260	410	199	100	260	247	12.5	6
XG80 80 100	45	20	85	M16	135	50	14.5	260	410	218	102	285	272	13	6
XG100 100 125	65	30	150	M20	220	70	25	340	560	258.5	115	337	324	17	10
XG125 125 135	65	30	150	M20	220	70	25	340	560	306	135	402.5	382	17	10