



**杭州宏昱传动设备有限公司**

地址: 杭州钱塘新区新湾工业园  
电话: 0571-82732832  
电话: 0571-83732832  
邮编: 311200

**HANGZHOU HONY TRANSMISSION CO.,LTD**

Add: Xinwan industry, QianTang New Distrist, HangZhou, China  
Tel: 0086-571-82732832  
Fax: 0086-571-83732832  
P.C.: 311200  
<http://www.hony-transmission.com>  
E-mail: tony@hony-transmission.com



**杭州宏昱传动设备有限公司**  
Hangzhou Hony Transmission Co.,Ltd

产品索引  
Product Indexes

- 02-03 ■ 企业介绍  
Company Introduction
- 05 ■ 产品结构图  
Product Structure Diagram
- 06 ■ 电动机标配轴承  
Motor Standard Bearings
- 06 ■ IE1(Y2)、IE2(YE2)、IE3(YE3)电机效率标准值  
IE1(Y2),IE2(YE2),IE3(YE3) Motor Efficiency Standard Value
- 07-08 ■ 硬齿轮面减速机专用电机  
Hardened Reducer Special Motor
- 09-16 ■ Y2、YE2、YE3系列三相异步电动机  
Y2, YE2, YE3 series Three-phase Induction Motor
- 17-20 ■ Y2EJ(YEJ)系列电磁制动三相异步电动机  
Y2EJ(YEJ) series Electromagnetic Breaking Three-phase Induction Motor
- 21-23 ■ YVF2(YVP)系列变频调速三相异步电动机  
YVF2(YVP) series Variable Frequency Adjustable Speed Three-phase Induction Motors
- 24-27 ■ YD系列变级多速三相异步电动机  
YD series Three Phase Multispeed Induction Motor
- 27-30 ■ YL、YC、YY系列铝壳单相异步电动机  
YL, YC, YY series Aluminium Single Phase Motor

产品结构图  
Product Structure Diagram

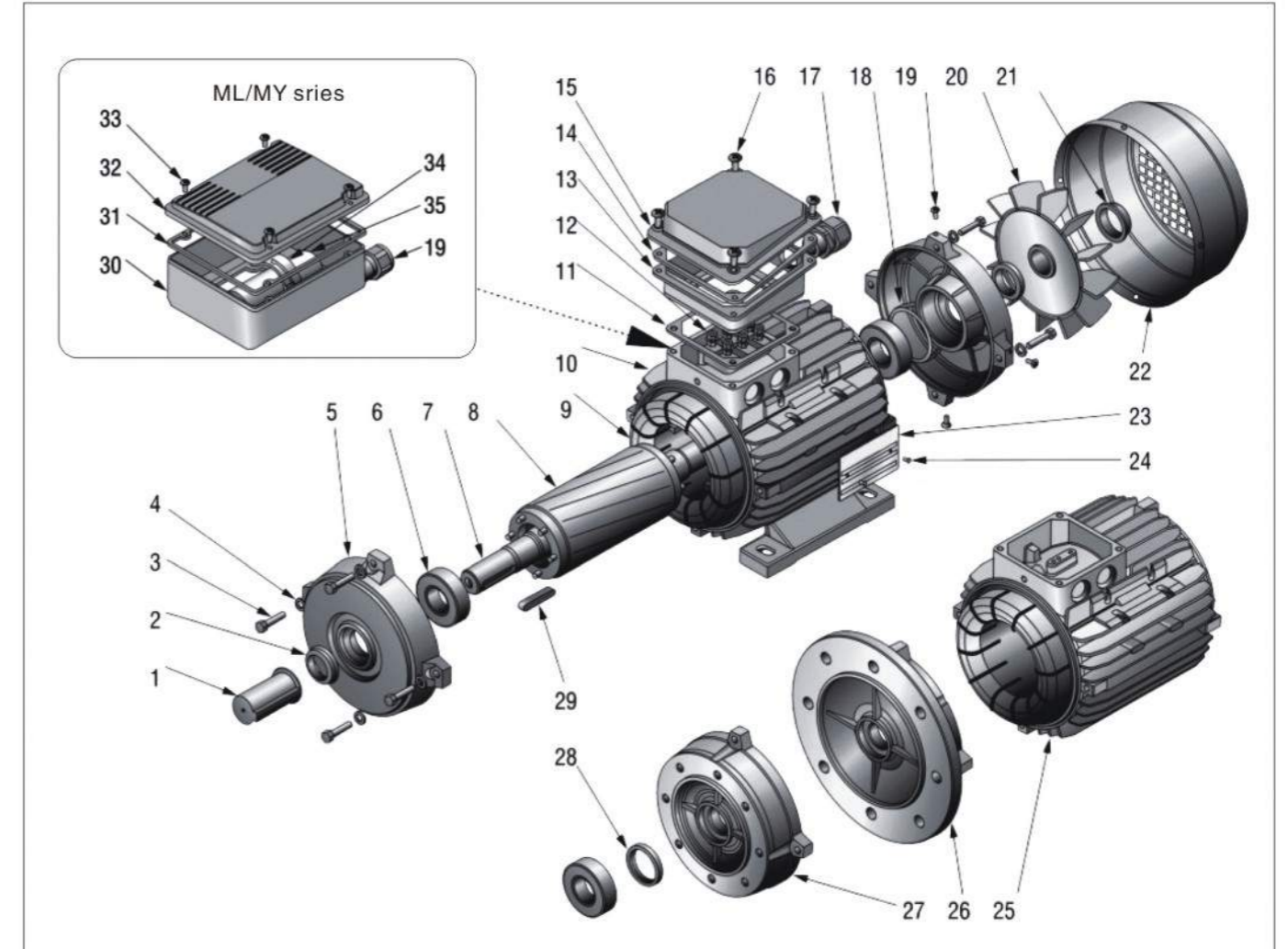

- |   |   |
|---|---|
| <ul style="list-style-type: none"> <li>1. 轴套 Shaft cover</li> <li>2. 甩水圈 V-ring</li> <li>3. 螺钉 Motor clamping screws</li> <li>4. 弹簧垫 Spring ring</li> <li>5. 端盖 Shled</li> <li>6. 轴承 Bearing</li> <li>7. 转轴 Motor shaft</li> <li>8. 转子 Rotor</li> <li>9. 定子绕组 Wound stator</li> <li>10. 机壳 Motor casing</li> <li>11. 橡胶垫 IP55 gasket</li> <li>12. 接线板 Mains power connection terminal block</li> <li>13. 接线盒 Terminal block box-base</li> <li>14. IP55橡胶垫 IP65 gasket</li> <li>15. 接线盒盖 Terminal block box-cover</li> <li>16. 螺钉 Terminal block box tightening screws</li> <li>17. 出线螺套 Cable inlet bush</li> <li>18. 波形垫片 Compensatlon ring</li> </ul> | <ul style="list-style-type: none"> <li>19. 螺钉 Fan cover tightening screws</li> <li>20. 风叶 PVC fan</li> <li>21. 卡圈 Ring for fan tightening</li> <li>22. 风罩 Fan cover</li> <li>23. 铭牌 Motor identification plate</li> <li>24. 铭牌铆钉 Motor identification plate tightening screws</li> <li>25. B5机壳 B5 motor casing</li> <li>26. B5法兰 B5 flange</li> <li>27. B14法兰 B14 flange</li> <li>28. 密封圈 Sealing ring</li> <li>29. 轴键 Shaft key</li> <li>30. 电容盒座 Capacitor-holder-base vers. MM</li> <li>31. IP55橡胶垫 IP55 gasket vers. MM</li> <li>32. 电容盒盖 Capacitor-holder-cover vers. MM</li> <li>33. 螺钉 Capacitor-holder tightening screws vers. MM</li> <li>34. 电容扣 Capacitor clamp vers. MM</li> <li>35. 电容 Capacitor</li> </ul> |
|---|---|

## 电动机标配轴承 Motor Standard Bearings

我们的电动机配备C&U、NSK、SKF等品牌的标准轴承。  
所有轴承都安装了油封以保证电动机在各种环境下正常运作。  
机座为180及其以上的电动机都安装了加油孔。

Our motors are equipped as standard with bearings from C&U,NSK,SKF etc.  
All bearings are protected from the external environment with oil seals in the drive and non drive end.  
Grease nipple for frame size 180 and up.

机座号 Frame No.	轴伸端 Drive End		非轴伸端 Non-Drive End	
	2P	4、6、8P	2P	4、6、8P
56	6201	6201	6201	6201
63	6201	6201	6201	6201
71	6202	6202	6202	6202
80	6204	6204	6204	6204
90	6205	6205	6205	6205
100	6206	6206	6206	6206
112	6306	6306	6306	6306
132	6308	6308	6308	6308
160	6309	6309	6309	6309
180	6311	6311	6311	6311
200	6312	6312	6312	6312
225	6313	6313	6313	6313
250	6314	6314	6314	6314
280	6314	6317	6314	6317
315	6317	6319	6317	6319
355	6319	6322	6319	6322

## IE1(Y2)、IE2(YE2)、IE3(YE3)电机效率标准值 IE1(Y2),IE2(YE2),IE3(YE3) Motor Efficiency Standard Value

电机功率 (KW)	2极 Poles			4极 Poles			6极 Poles		
	IE1	IE2	IE3	IE1	IE2	IE3	IE1	IE2	IE3
0.75	72.1	77.4	80.7	72.1	79.6	82.5	70	75.9	78.9
1.1	75	79.6	82.7	75	81.4	84.1	72.9	78.1	81
1.5	77.2	81.3	84.2	77.2	82.8	85.3	75.2	79.8	82.5
2.2	79.7	83.2	85.9	79.7	84.3	86.7	77.7	81.8	84.3
3	81.5	84.6	87.1	81.5	85.5	87.7	79.7	83.3	85.6
4	83.1	85.8	88.1	83.1	86.6	88.6	81.4	84.6	86.8
5.5	84.7	87	89.2	84.7	87.7	89.6	83.1	86	88
7.5	86	88.1	90.1	86	88.7	90.4	84.7	87.2	89.1
11	87.6	89.4	91.2	87.6	89.8	91.4	86.4	88.7	90.3
15	88.7	90.3	91.9	88.7	90.6	92.1	88.7	89.7	91.2
18.5	89.3	90.9	92.4	89.3	91.2	92.6	88.6	90.4	91.7
22	89.9	91.3	92.7	89.9	91.6	93	89.2	90.9	92.2
30	90.7	92	93.3	90.7	92.3	93.6	90.2	91.7	92.9
37	91.2	92.5	93.7	91.2	92.7	93.9	90.8	92.2	93.9
45	91.7	92.9	94	91.7	93.1	94.2	91.4	92.7	93.7
55	92.1	93.2	94.3	92.1	93.5	94.6	91.9	93.1	94.1
75	92.7	93.8	94.7	92.7	94	95	92.6	93.7	94.6
90	93	94.1	95	93	94.2	95.2	92.6	94	94.9
110	93.3	94.3	95.2	93.3	94.5	95.4	93.3	94.3	95.1
132	93.5	94.6	95.4	93.5	94.7	95.6	93.5	94.6	95.4
160	93.8	94.8	95.6	93.8	94.9	95.8	93.8	94.8	95.6
200-375	94	95	95.8	94	95.1	96	94	95	95.8

## 硬齿面齿轮减速机专用电机 Hardened Reducer Special Motor

硬齿面R、S、F、K系列减速机专用Y2/YE2系列三相异步电动机是我公司为满足减速机特性需要专门设计的电动机。机座材料为铝压铸和灰铸铁两种，在凸缘端结构和轴承座上都做了改进和调节。在同一型号中可和多种凸缘端盖搭配，满足不同安装尺寸的要求。选用工字型凸缘端盖，转轴进行调质处理，同时加大轴承档次，可以提高轴承承载能力，增加安全系数及电机使用寿命。此结构型式适用Y2/YE2系列派生的YVF2系列变频调速电动机，Y2EJ系列电磁制动机以及YVF2EJ系列变频调速制动电动机。

Hardened R, S, F, K series reducer special for Y2/YE2 series three-phase asynchronous motor is my company in order to meet the need of design of reducer supporting door motor. In the flange end structure and bearing to cover are made improvements and regulation. In the same model and a variety of flange end cap collocation, to meet different installation requirements of the sizes of. Selection of I-shaped flange end cap, axle of quenching and tempering treatment, at the same time, increase the bearing quality, can improve the bearing capacity, the safety factor is increased and the service life of the motor. This structure suitable for Y2/YE2 series of derived YVF2 series variable frequency and variable speed motor, Y2/YEJ series and YVF2EJ series electromagnetic brake braking motor variable frequency speed control.

使用条件  
环境温度：-15℃~+40℃  
工作方式：S1（连续工作制）  
使用环境：海拔不超过1000m  
冷却方式：IC 0141（风扇自扇冷却）  
额定电压：380V（其它电压需另订协议）  
额定频率：50Hz、60Hz  
绝缘等级：F级  
防护等级：IP54、IP55

Operating Conditions  
Ambient temperature: -15℃~+40℃  
Duty: S1  
Altitude: Not exceed 1000m  
Cooling method: IC 0141 (Fan cooling fan)  
Rated voltage: 380V (Other voltages required separate agreement)  
Rated frequency: 50Hz, 60Hz  
Insulation class: F  
Protection class: IP54, IP55



硬齿面专用电机安装及外形尺寸  
Hardened gearbox special motor instruction and overall dimension

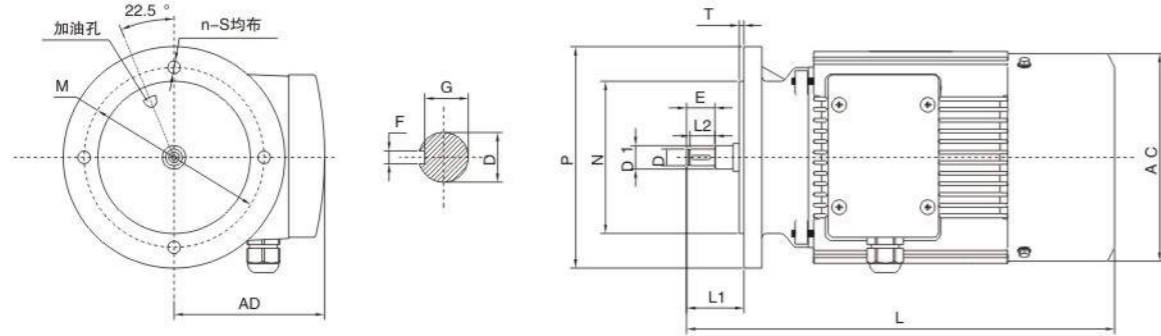

机座号	功率 (kw)	D	D1	L1	L2	E	P	M	N	T	S	n	G	F	AC	AD	L			
																	普通电机	制动电机	变频电机	变频制动电机
D71K4 D71C4 D71D4	0.18 0.25 0.37	10	14	36 41.5 41.5	17	18.5	120 160 200	100 130 165	80 110 130	3 3.5 3.5	6.6 9 11	4	8.6	2	150	108	293	345	333	402
D80K4 ~ D80N4	0.55 ~ 0.75	12	17	36 41.5 47.5 52.5	19	20.5	120 160 200 250	100 130 165 215	80 110 130 180	3 3.5 3.5 4	6.6 9 11 14	4	10	3	165	115	315	368	353	405
D90S4 ~ D90L4	1.1 ~ 1.5	14	20	36 41.5 47.5 53.5	21	22.5	120 160 200 250	100 130 165 215	80 110 130 180	3 3.5 3.5 4	6.6 9 11 14	4	12	3	180	123	354	406	383	462
D100M4 ~ D100L4	2.2 ~ 3	16	22	36 44 52 56 62 68	24	26	120 160 200 250 300 350	100 130 165 215 265 300	80 110 130 180 230 250	3 3.5 3.5 4 4 5	6.6 9 11 14 14 18	4	13.4	4	210	136	412	469	435	525
D112M4	4	18	25	44 52 56 63 69	27.2	29	160 200 250 300 350	130 165 215 265 300	110 130 180 230 250	3 3.5 4 4 5	9 11 14 14 18	4	15.4	4	232	150	441	504	464	554
D132S4 ~ D132M4 ~ D132L4	5.5 ~ 7.5 ~ 9.2	22	30	44 56 61 66 72 79 87	34.2	36	160 200 250 300 350 400 450	130 165 215 265 300 350 400	110 130 180 230 250 300 350	3 3.5 4 4 5 5 5	9 11 14 14 18 18 18	4	18.5	5	275	160	490	558	518	625
D160M4 D160L4 (铸铁壳)	11 15	28	36	61 66 71 77 84 92 100	37.5	41	200 250 300 400 450 550	165 215 265 350 400 450	130 180 230 300 350 450	3.5 4 4 5 5 5	11 14 14 18 18 18	4	23.9	6	330	330	160M:587 160L:631	160M:677 160L:721	160M:625 160L:669	160M:694 160L:738
D180M4 ~ D180L4 (铸铁壳)	18.5 ~ 22	32	40	66 71 77 84 92 100	37.5	41	250 300 350 400 450 550	215 265 300 350 400 500	180 230 250 300 350 450	4 4 5 5 5 5	14 14 18 18 18 18	4	27.3	8	380	280	180M:682 180L:720	180M:758 180L:796	180M:702 180L:740	180M:808 180L:846
D200L4 D225S4 D225M4 (铸铁壳)	30 37 45	38	50	71 77 84 92 100	37.5	41	300 350 400 450 550	350 400 450 500	230 250 300 350 450	4 4 5 5 5	14 18 18 18 18	4	33	10	200L:420 225机座: 470	200L:305 225机座: 335	200L:721 225S:756 225M:786	200L:847 225S:892 225M:922	200L:761 225S:803 225M:833	200L:858

Y2、YE2、YE3系列三相异步电动机  
Y2, YE2, YE3 series Three-phase Induction Motor

Y2、YE2、YE3系列三相异步电动机是鼠笼式低电压三相异步电动机，满足国内外的需求，符合国内外基座56-355范围的要求和国家统一标准设计。符合标准IEC60034-30-2008的相关规则。具有出色性能，效率高、节能、起动转矩大、噪声低、振动小、运行可靠、维修方便等。其安装尺寸和功率符合IEC标准。防护等级为IP44、IP54、IP55；冷却方式为IC411。根据能效可归类为IE1、IE2、IE3三个不同级别，根据材料和框架结构可以归类为铝壳和铁壳。

Y2, YE2, YE3 series three phase asynchronous motor is squirrel cage type low voltage three phase asynchronous motor. This series can meet requirement for general uses at home and abroad with frame range 56-355. Y2 motors are newly designed in conformity with the relevant rules of IEC60034-30-2008 standards. The motors have outstanding performance, such as high efficiency, energy saving, high starting torque, low noise, little vibration, reliable operation and easy maintenance, etc. It's mounting dimension and power totally conform to IEC standard. Protection Class: IP44, IP54, IP55; Cooling Method: IC41. According to power efficiency Y2 series three phase asynchronous motors could be classified to IE1, IE2, IE3 3 different levels, Based on materials and frame structure, motors could also be classified as Y2 Aluminum, Cast Iron etc.

Y2、YE2、YE3系列电动机广泛应用于众多无特殊要求的机械设备上，如机床、泵、风机、运输机械、搅拌机、农业机械和食品机械等。

Y2, Ye2, YE3 series motors are widely used in many mechanical equipments which has no special requirements, such as machine tools, pumps, fans, transport machinery, mixer, agriculture machinery and food machines, etc.

额定电压：380V、400V、415V、440V等(特殊电压可定做)  
功率：0.55-315KW  
频率：50Hz、60Hz  
防护等级：B、F、H  
连接方式：3KW以下Y接法；3KW以上Δ接法

Rated Voltage: 380v; 400v; 415v; 440v etc  
(Special voltage is available on request)  
Power: 0.55-315KW  
Frequency: 50Hz, 60Hz  
Insulation Class: B, F, H  
Connection Type: Power onder 3KW selects Star connection  
Power up 3KE selects Delta connection.



IE1(Y2)系列(56-355)电机技术数据表 Motor technical data sheet

Type	(kW)	η (%)	Cos φ	r/min	Rated current(A)			Ts/Tn	Tmax/Tn	Is/In	铝重	铁重	dB(A)
					380	400	415						
56M1-2	0.09	62	0.7	2750	0.3	0.3	0.3	2.1	2.2	5.2	3.6	/	58
56M2-2	0.12	67	0.72	2750	0.4	0.4	0.3	2.1	2.2	5.2	3.9	/	58
63M1-2	0.18	65	0.8	2730	0.5	0.5	0.5	2.2	2.2	5.5	4.8	/	61
63M2-2	0.25	68	0.81	2800	0.7	0.7	0.6	2.2	2.2	5.5	5.1	/	61
71M1-2	0.37	70	0.81	2756	1.0	0.9	0.9	2.2	2.2	6.1	6	15	64
71M2-2	0.55	72	0.82	2792	1.4	1.3	1.3	2.2	2.2	6.1	6.5	15.5	64
80M1-2	0.75	72.1	0.83	2830	1.9	1.8	1.7	2.2	2.3	6.1	8.7	16	67
80M2-2	1.1	75	0.84	2830	2.7	2.5	2.4	2.2	2.3	7	9.5	17	67
90S-2	1.5	77.2	0.84	2840	3.5	3.3	3.2	2.2	2.3	7	11.8	22	72
90L-2	2.2	79.7	0.85	2840	4.9	4.7	4.5	2.2	2.3	7	13.5	25	72
100L-2	3	81.5	0.87	2860	6.4	6.1	5.9	2.2	2.3	7.5	21	33	76
112M-2	4	83.1	0.88	2880	8.3	7.9	7.6	2.2	2.3	7.5	28	45	77
132S1-2	5.5	84.7	0.88	2900	11.2	10.7	10.3	2.2	2.3	7.5	39	64	80
132S2-2	7.5	86	0.88	2900	15.1	14.3	13.8	2.2	2.3	7.5	44.5	70	80
160M1-2	11	87.6	0.89	2930	21.4	20.4	19.6	2.2	2.3	7.5	69.5	117	86
160M2-2	15	88.7	0.89	2930	28.9	27.4	26.4	2.2	2.3	7.5	78	125	86
160L-2	18.5	89.3	0.9	2930	35.0	33.2	32.0	2.2	2.3	7.5	88.5	147	86
180M-2	22	89.9	0.9	2940	41.3	39.2	37.8	2	2.3	7.5	/	180	89
200L1-2	30	90.7	0.9	2950	55.8	53.0	51.1	2	2.3	7.5	/	240	92
200L2-2	37	91.2	0.9	2950	68.5	65.1	62.7	2	2.3	7.5	/	255	92
225M-2	45	91.7	0.9	2970	82.8	78.7	75.9	2	2.3	7.5	/	309	92
250M-2	55	92.1	0.9	2970	100.8	95.8	92.3	2	2.3	7.5	/	403	93
280S-2	75	92.7	0.9	2970	136.6	129.8	125.1	2	2.3	7.5	/	544	94
280M-2	90	93	0.91	2970	161.6	153.5	148.0	2	2.3	7.5	/	620	94
315S-2	110	93.3	0.91	2980	196.9	187.0	180.2	1.8	2.2	7.1	/	980	96
315M-2	132	93.5	0.91	2980	235.7	223.9	215.8	1.8	2.2	7.1	/	1080	96
315L1-2	160	93.8	0.92	2980	281.7	267.6	257.9	1.8	2.2	7.1	/	1160	99
315L2-2	200	94	0.92	2980	351.4	333.8	321.7	1.8	2.2	7.1	/	1190	99
355M-2	250	94	0.92	2980	439.2	417.3	402.2	1.6	2.2	7.1	/	1760	103
355L-2	315	94	0.92	2980	553.4	525.8	506.8	1.6	2.2	7.1	/	1850	103
56M1-4	0.06	56	0.58	1325	0.3	0.3	0.3	2	2.1	3.9	3.6	/	48
56M2-4	0.09	58	0.61	1325	0.4	0.4	0.4	2	2.1	3.9	3.9	/	48
63M1-4	0.12	57	0.72	1320	0.4	0.4	0.4	2.1	2.2	4.4	4.8	/	52
63M2-4	0.18	60	0.73	1320	0.6	0.6	0.6	2.1	2.2	4.4	5.1	/	52
71M1-4	0.25	65	0.74	1347	0.8	0.8	0.7	2.1	2.2	5.2	6	14	55
71M2-4	0.37	67	0.75	1340	1.1	1.1	1.0	2.1	2.2	5.2	6.3	14.5	55
80M1-4	0.55	71	0.75	1390	1.6	1.5	1.4	2.4	2.3	5.2	9.4	17	58
80M2-4	0.75	72.1	0.76	1390	2.1	2.0	1.9	2.3	2.3	6	10	18	58
90S-4	1.1	75	0.77	1390	2.9	2.7	2.6	2.3	2.3	6	12	22	61
90L-4	1.5	77.2	0.79	1390	3.7	3.6	3.4	2.3	2.3	6	14	27	61
100L1-4	2.2	79.7	0.81	1410	5.2	4.9	4.7	2.3	2.3	7	21	34	64
100L2-4	3	81.5	0.82	1410	6.8	6.5	6.2	2.3	2.3	7	23.5	38	64
112M-4	4	83.1	0.82	1435	8.9	8.5	8.2	2.3	2.3	7	29.5	43	65
132S-4	5.5	84.7	0.83	1440	11.9	11.3	10.9	2.3	2.3	7	41	68	71
132M-4	7.5	86	0.84	1440	15.8	15.0	14.4	2.3	2.3	7	47.5	81	71
160M-4	11	87.6	0.84	1460	22.7	21.6	20.8	2.2	2.3	7	72.5	123	75
160L-4	15	88.7	0.85	1460	30.2	28.7	27.7	2.2	2.3	7.5	85.5	144	75
180M-4	18.5	89.3	0.86	1470	36.6	34.8	33.5	2.2	2.3	7.5	/	182	76
180L-4	22	89.9	0.88	1470	43.3	41.1	39.6	2.2	2.3	7.5	/	190	76
200L-4	30	90.7	0.86	1470	58.4	55.5	53.5	2.2	2.3	7.2	/	270	79
225S-4	37	91.2	0.87	1480	70.9	67.3	64.9	2.2	2.3	7.2	/	284	81
225M-4	45	91.7	0.87	1480	85.7	81.4	78.5	2.2	2.3	7.2	/	320	81
250M-4	55	92.1	0.87	1480	104.3	99.1	95.5	2.2	2.3	7.2	/	427	83
280S-4	75	92.7	0.87	1480	141.3	134.2	129.4	2.2	2.3	7.2	/	562	86
280M-4	90	93	0.87	1480	169.0	160.6	154.8	2.2	2.3	7.2	/	667	86
315S-4	110	93.3	0.88	1490	203.6	193.4	186.4	2.1	2.2	6.9	/	1000	93
315M-4	132	93.5	0.88	1490	243.8	231.6	223.2	2.1	2.2	6.9	/	1100	93
315L1-4	160	93.8	0.89	1490	291.2	276.6	266.6	2.1	2.2	6.9	/	1160	97
315L2-4	200	94	0.89	1490	363.2	345.1	332.6	2.1	2.2	6.9	/	1270	97
355M-4	250	94	0.9	1490	449.0	426.5	411.1	2.1	2.2	6.9	/	1700	101
355L-4	315	94	0.9	1490	565.7	537.4	518.0	2.1	2.2	6.9	/	1850	101

IE1(Y2)系列(56-355)电机技术数据表 Motor technical data sheet

Type	(kW)	η (%)	Cos φ	r/min	Rated current(A)			Ts/Tn	Tmax/Tn	Is/In	铝重	铁重	dB(A)
					380	400	415						
71M1-6	0.18	56	0.66	865	0.7	0.7	0.7	1.9	2	4	6	14	52
71M2-6	0.25	59	0.68	863	0.9	0.9	0.9	1.9	2	4	6.3	14.5	52
80M-6	0.37	62	0.7	890	1.3	1.2	1.2	1.9	2	4.7	8.9	17	54
80M2-6	0.55	65	0.72	890	1.8	1.7	1.6	1.9	2	4.7	10.4	19	54
90S-6	0.75	70	0.72	910	2.3	2.1	2.1	2	2.1	5.5	12.1	23	57
90L-6	1.1	72.9	0.73	910	3.1	3.0	2.9	2	2.1	5.5	13.7	25	57
100L-6	1.5	75.2	0.75	920	4.0	3.8	3.7	2	2.1	5.5	23	33	61
112M-6	2.2	77.7	0.76	935	5.7	5.4	5.2	2	2.1	6.5	28.2	45	65
132S-6	3	79.7	0.76	960	7.5	7.1	6.9	2.1	2.1	6.5	40.3	63	69
132M1-6	4	81.4	0.76	960	9.8	9.3	9.0	2.1	2.1	6.5	43	73	69
132N2-6	5.5	83.1	0.77	960	13.1	12.4	12.0	2.1	2.1	6.5	47.2	84	69
160M-6	7.5	84.7	0.77	970	17.5	16.6	16.0	2	2.1	6.5	70.6	119	73
160L-6	11	86.4	0.78	970	24.8	23.6	22.7	2	2.1	6.5	85	147	73
180L-6	15	88.7	0.81	970	31.7	30.1	29.0	2	2.1	7	/	195	73
200L1-6	18.5	88.6	0.81	970	39.2	37.2	35.9	2.1	2.1	7	/	220	76
200L2-6	22	89.2	0.83	970	45.1	42.9	41.3	2.1	2.1	7	/	250	76
225M-6	30	90.2	0.84	980	60.2	57.2	55.1	2	2.1	7	/	292	76
250M-6	37	90.8	0.86	980	72.0	68.4	65.9	2.1	2.1	7	/	408	78
280S-6	45	91.4	0.86	980	87.0	82.6	79.6	2.1	2	7	/	536	80
280M-6	55	91.9	0.86	980	105.7	100.4	96.8	2.1	2	7	/	595	80
315S-6	75	92.6	0.86	990	143.0	135.9	131.0	2	2	7	/	990	85
315M-6	90	92.9	0.86	990	171.2	162.6	156.7	2	2	7	/	1080	85
315L1-6	110	93.3	0.86	990	208.3	194.9	190.7	2	2	6.7	/	1150	85
315L2-6	132	93.5	0.87	990	246.6	234.2	225.8	2	2	6.7	/	1210	85
355M1-6	160	93.8	0.88	990	294.5	279.8	269.7	1.9	2	6.7	/	1600	92
355M3-6	200	94	0.88	990	367.4	349.0	336.4	1.9	2	6.7	/	1700	92
355L2-6	250	94	0.88	990	459.2	436.2	420.5	1.9	2	6.7	/	1800	92
80M1-8	0.18	51	0.61	630	0.9	0.8	0.8	1.8	1.9	3.3	9	17	52
80M2-8	0.25	54	0.61	640	1.2	1.1	1.1	1.8	1.9	3.3	10.5	19	52
90S-8	0.37	62	0.61	660	1.5	1.4	1.4	1.8	1.9	4	12	23	56
90L-8	0.55	63	0.61	660	2.2	2.1	2.0	1.8	2	4	13.5	25	56
100L1-8	0.75	71	0.67	690	2.4	2.3	2.2	1.8	2	4	23	33	59
100L2-8	1.1	73	0.69	690	3.3	3.2	3.0	1.8	2	5	25	38	59
112M-8	1.5	75	0.69	680	4.4	4.2	4.0	1.8	2	5	28	50	61
132S-8	2.2	78	0.71	710	6.0	5.7	5.5	1.8	2	6	40	63	64
132M-8	3	79	0.73	710	7.9	7.5	7.2	1.8	2	6	45	79	64

IE2(YE2)系列(80-355)电机技术数据表 Motor technical data sheet

Type	(kW)	η(%)	Cos φ	r/min	Rated current(A)			Ts/Tn	Tmax/Tn	Is/In	铝重	铁重
					380	400	415					
801-2	0.75	77.4	0.83	2875	1.8	1.7	1.6	2.5	3	5.3	10.5	18
802-2	1.1	79.6	0.84	2888	2.5	2.4	2.3	3.2	3.8	7	11.2	19
90S-2	1.5	81.3	0.84	2887	3.3	3.2	3.1	2.7	3.5	7.1	14.5	25
90L-2	2.2	83.2	0.85	2889	4.7	4.5	4.3	2.4	3	6.9	16.8	28
100L-2	3	84.6	0.87	2890	6.2	5.9	5.7	3.2	4	8	21.5	34
112M-2	4	85.8	0.88	2901	8.0	7.6	7.4	2.5	3	7.5	27.5	45
132S1-2	5.5	87	0.88	2915	10.9	10.4	10.0	2.7	3.5	7.5	41.5	67
132S2-2	7.5	88.1	0.88	2915	14.7	14.0	13.5	2.4	3.3	7.5	47	73
160M1-2	11	89.4	0.89	2930	21.0	20.0	19.2	2.2	2.9	7.6	72	123
160M2-2	15	90.3	0.89	2940	28.4	26.9	26.0	2.3	3	7.6	83	127
160L-2	18.5	90.9	0.9	2940	34.4	32.6	31.5	2.3	3.1	7.4	90	158
180M-2	22	91.3	0.9	2945	40.7	38.6	37.2	2.8	3	8.2	/	190
200L1-2	30	92	0.9	2950	55.1	52.3	50.4	2.6	3	7.8	/	256
200L2-2	37	92.5	0.9	2955	67.5	64.2	61.8	2.6	3	7.7	/	265
225M-2	45	92.9	0.9	2975	81.8	77.7	74.9	2.4	2.6	7.5	/	332
250M-2	55	93.2	0.9	297	99.6	94.6	91.2	2.3	2.8	7.1	/	423
280S-2	75	93.8	0.9	2985	135.0	128.2	123.6	2.5	2.8	7.4	/	592
280M-2	90	94.1	0.91	2972	159.7	151.7	146.2	2.8	2.8	7.6	/	690
315S-2	110	94.3	0.91	2982	194.8	185.0	178.3	2.4	2.9	6.9	/	1110
315M-2	132	94.6	0.91	2982	233.0	221.3	213.3	2.6	2.9	7.1	/	1222
315L1-2	160	94.8	0.92	2979	278.7	264.8	255.2	2.5	2.8	7.1	/	1230
315L2-2	200	95	0.92	2979	347.7	330.3	318.4	2.5	2.8	6.9	/	1270
355M-2	250	95	0.92	2979	434.6	412.9	398.0	2.5	2.8	7	/	1800
355L-2	315	95	0.92	2979	547.6	520.2	501.4	2.5	2.9	6.9	/	1900
802-4	0.75	79.6	0.76	1428	1.9	1.8	1.7	2.4	2.9	5	10.5	18
90S-4	1.1	81.4	0.77	1431	2.7	2.5	2.4	3	3.5	6	15	25
90L-4	1.5	82.8	0.79	1438	3.5	3.3	3.2	3.2	3.8	6.8	17.5	31
100L1-4	2.2	84.3	0.81	1441	4.9	4.7	4.5	3	3.5	7	24	37
100L2-4	3	85.5	0.82	1429	6.5	6.2	6.0	2.6	3.3	7	25	40
112M-4	4	86.6	0.82	1444	8.6	8.1	7.8	3.5	4	7.5	32	46
132S-4	5.5	87.7	0.83	1456	11.5	10.9	10.5	2.2	2.8	6.4	46	73
132M-4	7.5	88.7	0.84	1455	15.3	14.5	14.0	2.4	3	7	54	88
160M-4	11	89.8	0.84	1470	22.2	21.0	20.3	2.5	2.9	6.9	77	134
160L-4	15	90.6	0.85	1470	29.6	28.1	27.1	2.5	3	7.5	90	153
180M-4	18.5	91.2	0.86	1475	35.8	34.0	32.8	2.6	3.1	7.8	/	194
180L-4	22	91.6	0.86	1475	42.4	40.3	38.9	2.6	3.1	7.5	/	198
200L-4	30	92.3	0.86	1480	57.4	54.6	52.6	2.4	2.9	7.1	/	293
225S-4	37	92.7	0.87	1485	69.7	66.2	63.8	2.5	2.7	7.5	/	298
225M-4	45	93.1	0.87	1485	84.4	80.2	77.3	2.5	2.8	7.6	/	335
250M-4	55	93.5	0.87	1480	102.7	97.6	94.1	2.6	2.7	7.3	/	462
280S-4	75	94	0.87	1485	139.3	132.4	127.6	2.7	2.7	7.6	/	582
280M-4	90	94.2	0.87	1489	166.9	158.5	152.8	2.7	2.7	7.5	/	717
315S-4	110	94.5	0.88	1492	201.0	190.9	184.0	2.7	2.9	7.1	/	1128
315M-4	132	94.7	0.88	1486	240.7	228.6	220.4	2.7	2.9	7.3	/	1201
315L1-4	160	94.9	0.88	1486	287.8	273.4	263.6	3	3	7.4	/	1210
315L2-4	200	95.1	0.88	1487	359.0	341.1	328.7	3	3	7.6	/	1368
355M-4	250	95.1	0.9	1485	443.8	421.6	406.4	2.8	2.9	7.5	/	1740
355L-4	315	95.1	0.9	1490	559.2	531.2	512.0	2.6	2.8	7.4	/	1800
90S-6	0.75	75.9	0.72	944	3.4	2.0	1.9	2.2	2.4	4.5	13.5	24
90L-6	1.1	78.1	0.73	928	4.7	2.8	2.7	2.4	2.6	4.5	18	29
100L-6	1.5	79.8	0.75	939	6.2	3.6	3.5	1.8	2.2	4.2	22.5	33
112M-6	2.2	81.8	0.76	936	8.7	5.1	4.9	2.3	2.8	4.5	27	45
132S-6	3	83.3	0.76	960	11.7	6.8	6.6	1.8	2.4	4.5	38.5	63
132M1-6	4	84.6	0.76	957	15.3	9.0	8.7	2.3	2.7	5	44.5	75
132M2-6	5.5	86	0.77	962	20.5	12.0	11.6	1.9	2.8	5.5	52.5	86
160M-6	7.5	87.2	0.77	975	27.5	16.1	15.5	2	3	6.5	77	128
160L-6	11	88.7	0.78	975	39.3	22.9	22.1	2.4	3.3	7.5	90	159
180L-6	15	89.7	0.81	975	51.1	29.8	28.7	2	2.7	6.4	/	209
200L1-6	18.5	90.4	0.81	985	62.7	36.5	35.1	2.3	3	7	/	222
200L2-6	22	90.9	0.83	980	72.3	42.1	40.6	2.3	2.8	7	/	267
225M-6	30	91.7	0.84	985	96.9	56.2	54.2	2.2	2.7	6.5	/	282
250M-6	37	92.2	0.86	985	118.1	67.4	64.9	2.5	2.7	6.9	/	443
280S-6	45	92.7	0.86	990	140.5	81.5	78.5	2.2	2.4	7	/	566
280M-6	55	93.1	0.86	994	171.2	99.2	95.6	2.4	2.5	7.1	/	631
315S-6	75	93.7	0.86	992	232.4	134.3	129.5	2.8	3	7.3	/	1140
315M-6	90	94	0.86	991	278.0	160.7	154.9	2.7	2.9	7.1	/	1207
315L1-6	110	94.3	0.86	991	338.0	195.8	188.7	2.9	2.9	7.4	/	1234
315L2-6	132	94.6	0.87	990	400.9	231.5	223.1	3	3.1	7.6	/	1320
355M1-6	160	94.8	0.88	990	480.4	276.8	266.8	3.1	3.1	7.6	/	1550
355M3-6	200	95	0.88	991	600.5	345.3	332.8	3	3.1	7.8	/	1700
355L2-6	250	95	0.88	992	750.7	431.6	416.0	3.1	3	7.7	/	1900

IE3(YE3)系列(80-355)电机技术数据表 Motor technical data sheet

Type	(kW)	η(%)	Cos φ	r/min	Rated current(A)			Ts/Tn	Tmax/Tn	Is/In
					380	400	415			
80M1-2	0.75	80.7	0.83	2880	1.70	1.62	1.56	2.2	2.3	7
80M2-2	1.1	82.7	0.84	2880	2.41	2.29	2.20	2.2	2.3	7.9
90S-2	1.5	84.2	0.84	2895	3.22	3.06	2.95	2.2	2.3	7.9
90L-2	2.2	85.9	0.85	2985	4.58	4.35	4.19	2.2	2.3	7.9
100L-2	3	87.1	0.87	2895	6.02	5.71	5.51	2.2	2.3	8.1
112M-2	4	81.5	0.87	2905	8.57	8.14	7.85	2.2	2.3	8.1
132S1-2	5.5	89.2	0.88	2930	10.65	10.11	9.75	2.2	2.3	8.1
132S2-2	7.5	90.1	0.88	2930	14.37	13.65	13.16	2.2	2.3	8.1
160M1-2	11	91.2	0.89	2945	20.59	19.56	18.85	2.2	2.3	8.1
160M2-2	15	91.9	0.89	2945	27.86	26.47	25.51	2.2	2.3	8.1
160L-2	18.5	92.4	0.9	2955	33.80	32.11	30.95	2.2	2.3	8.1
180M-2	22	92.7	0.9	2955	40.07	38.06	36.69	2	2.3	8.1
200L1-2	30	93.3	0.9	2960	54.28	51.57	49.71	2	2.3	8.1
200L2-2	37	93.7	0.9	2960	66.66	63.33	61.04	2	2.3	8.1
225M-2	45	94	0.9	2965	80.82	76.78	74.00	2	2.3	8.1
250M-2	55	94.3	0.9	2970	98.46	93.54	90.16	2	2.3	8.1
280S-2	75	94.7	0.9	2975	133.70	127.02	122.43	2	2.3	8.1
280M-2	90	95	0.91	2975	158.18	150.27	144.84	2	2.3	8.1
315S-2	110	95.2	0.91	2978	192.92	183.28	176.65	1.8	2.2	7.7
315M-2	132	95.4	0.91	2978	231.02	219.47	211.54	1.8	2.2	7.7
315L1-2	160	95.6	0.92	2980	276.40	262.58	253.09	1.8	2.2	7.7
315L2-2	200	95.8	0.92	2980	344.78	327.54	315.70	1.8	2.2	7.7
355M-2	250	95.8	0.92	2982	430.98	409.43	394.63	1.6	2.2	7.7
355L-2	315	95.8	0.92	2982	543.03	515.88	497.23	1.6	2.2	7.7
802-4	0.75	82.5	0.76	1420	1.82	1.73	1.66	2.3	2.3	6.5
90S-4	1.1	84.1	0.77	1445	2.58	2.45	2.36	2.3	2.3	6.5
90L-4	1.5	85.3	0.79	1445	3.38	3.21	3.10	2.3	2.3	6.5
100L1-4	2.2	86.7	0.81	1435	4.76	4.52	4.36	2.3	2.3	7.5
100L2-4	3	87.7	0.82	1435	6.34	6.02	5.80	2.3	2.3	7.5
112M-4	4	88.6	0.82	1440	8.37	7.95	7.66	2.3	2.3	7.5
132S-4	5.5	89.6	0.83	1460	11.24	10.68	10.29	2.3	2.3	7.5
132M-4	7.5	90.4	0.84	1460	15.01	14.26	13.74	2.3	2.3	7.5
160M-4	11	91.4	0.84	1465	21.77	20.68	19.93	2.2	2.3	8.9
160L-4	15	92.1	0.85	1465	29.11	27.66	26.66	2.2	2.3	8.9
180M-4	18.5	92.6	0.86	1470	35.30	33.53				

YE2/Y2铁壳系列电机安装及外形尺寸  
YE2/Y2 Cast iron series motor instruction and overall dimension

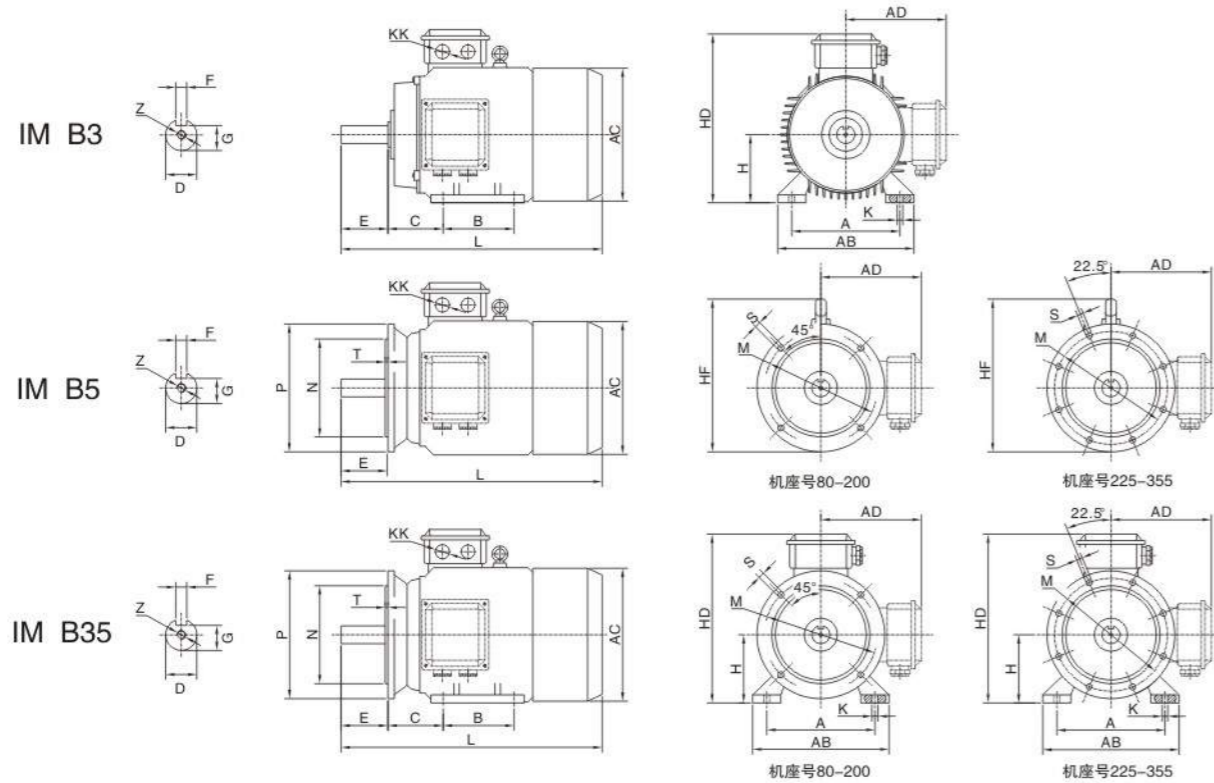

机座号 Frame No.	安装尺寸 Mounting Dimensions															外形尺寸 Overall Dimensions						
	A	B	C	D	E	F	G	H	K	Z	KK	P	M	N	S	T	AB	AC	AD	HD	HF	L
80M	125	100	50	19	40	6	15.5	80	10	M6 x 16	1-M20 x 1.5	200	165	130	12	3.5	165	175	145	220	185	295
90S	140	100	56	24	50	8	20	90	10	M8 x 19	1-M20 x 1.5	200	165	130	12	3.5	180	195	155	250	195	320
90L	140	125	56	24	50	8	20	90	10	M8 x 19	1-M20 x 1.5	200	165	130	12	3.5	180	195	155	250	195	345
100L	160	140	63	28	60	8	24	100	12	M10 x 22	1-M20 x 1.5	250	215	180	15	4	205	215	180	270	245	385
112M	190	140	70	28	60	8	24	112	12	M10 x 22	2-M25 x 1.5	250	215	180	15	4	230	240	190	300	265	400
132S	216	140	89	38	80	10	33	132	12	M12 x 28	2-M25 x 1.5	300	265	230	15	4	270	275	210	345	315	470
132M	216	178	89	38	80	10	33	132	12	M12 x 28	2-M25 x 1.5	300	265	230	15	4	270	275	210	345	315	510
160M	254	210	108	42	110	12	37	160	15	M12 x 28	2-M25 x 1.5	350	300	250	19	5	320	330	255	420	385	615
160L	254	254	108	42	110	12	37	160	15	M12 x 28	2-M25 x 1.5	350	300	250	19	5	320	330	255	420	385	670
180M	279	241	121	48	110	14	42.5	180	15	M12 x 28	2-M25 x 1.5	350	300	250	19	5	355	380	280	455	430	700
180L	279	279	121	48	110	14	42.5	180	15	M12 x 28	2-M25 x 1.5	350	300	250	19	5	355	380	280	455	430	740
200L	318	305	133	55	110	16	49	200	19	M20 x 42	2-M50 x 1.5	400	350	300	19	5	395	420	305	505	480	770
225S(4-8P)	356	286	149	60	140	18	53	225	19	M20 x 42	2-M50 x 1.5	450	400	350	19	5	435	470	335	560	530	815
225M(2P)	356	311	149	55	110	16	49	225	19	M20 x 42	2-M50 x 1.5	450	400	350	19	5	435	470	335	560	530	820
225M(4-8P)	356	311	149	60	140	18	53	225	19	M20 x 42	2-M50 x 1.5	450	400	350	19	5	435	470	335	560	530	845
250M(2P)	406	349	168	60	140	18	53	250	24	M20 x 42	2-M63 x 1.5	550	500	450	19	5	490	510	370	615	595	910
250M(4-8P)	406	349	168	65	140	18	58	250	24	M20 x 42	2-M63 x 1.5	550	500	450	19	5	490	510	370	615	595	910
280S(2P)	457	368	190	65	140	18	58	280	24	M20 x 42	2-M63 x 1.5	550	500	450	19	5	550	580	410	680	650	985
280M(2P)	457	419	190	65	140	18	58	280	24	M20 x 42	2-M63 x 1.5	550	500	450	19	5	550	580	410	680	650	1035
280S(4-8P)	457	368	190	75	140	20	67.5	280	24	M20 x 42	2-M63 x 1.5	550	500	450	19	5	550	580	410	680	650	985
280M(4-8P)	457	419	190	75	140	20	67.5	280	24	M20 x 42	2-M63 x 1.5	550	500	450	19	5	550	580	410	680	650	1035
315S(2P)	508	406	216	65	140	18	58	315	28	M20 x 42	2-M63 x 1.5	660	600	550	24	6	635	645	530	845		1240
315M(2P)	508	457	216	65	140	18	58	315	28	M20 x 42	2-M63 x 1.5	660	600	550	24	6	635	645	530	845		1350
315L(2P)	508	508	216	65	140	18	58	315	28	M20 x 42	2-M63 x 1.5	660	600	550	24	6	635	645	530	845		1350
315S(4-10P)	508	406	216	80	170	22	71	315	28	M20 x 42	2-M63 x 1.5	660	600	550	24	6	635	645	530	845		1380
315M(4-10P)	508	457	216	80	170	22	71	315	28	M20 x 42	2-M63 x 1.5	660	600	550	24	6	635	645	530	845		1380
315L(4-10P)	508	508	216	80	170	22	71	315	28	M20 x 42	2-M63 x 1.5	660	600	550	24	6	635	645	530	845		1380
355M(2P)	610	560	254	75	140	20	67.5	355	28	M20 x 42	2-M63 x 1.5	800	740	680	24	6	730	710	655	1010		1500
355L(2P)	610	630	254	75	140	20	67.5	355	28	M20 x 42	2-M63 x 1.5	800	740	680	24	6	730	710	655	1010		1500
355M(4-10P)	610	560	254	95	170	25	86	355	28	M20 x 42	2-M63 x 1.5	800	740	680	24	6	730	710	655	1010		1530
355L(4-10P)	610	630	254	95	170	25	86	355	28	M20 x 42	2-M63 x 1.5	800	740	680	24	6	730	710	655	1010		1530

YE2/Y2铝壳系列电机安装及外形尺寸  
YE2/Y2 Aluminium series motor instruction and overall dimension

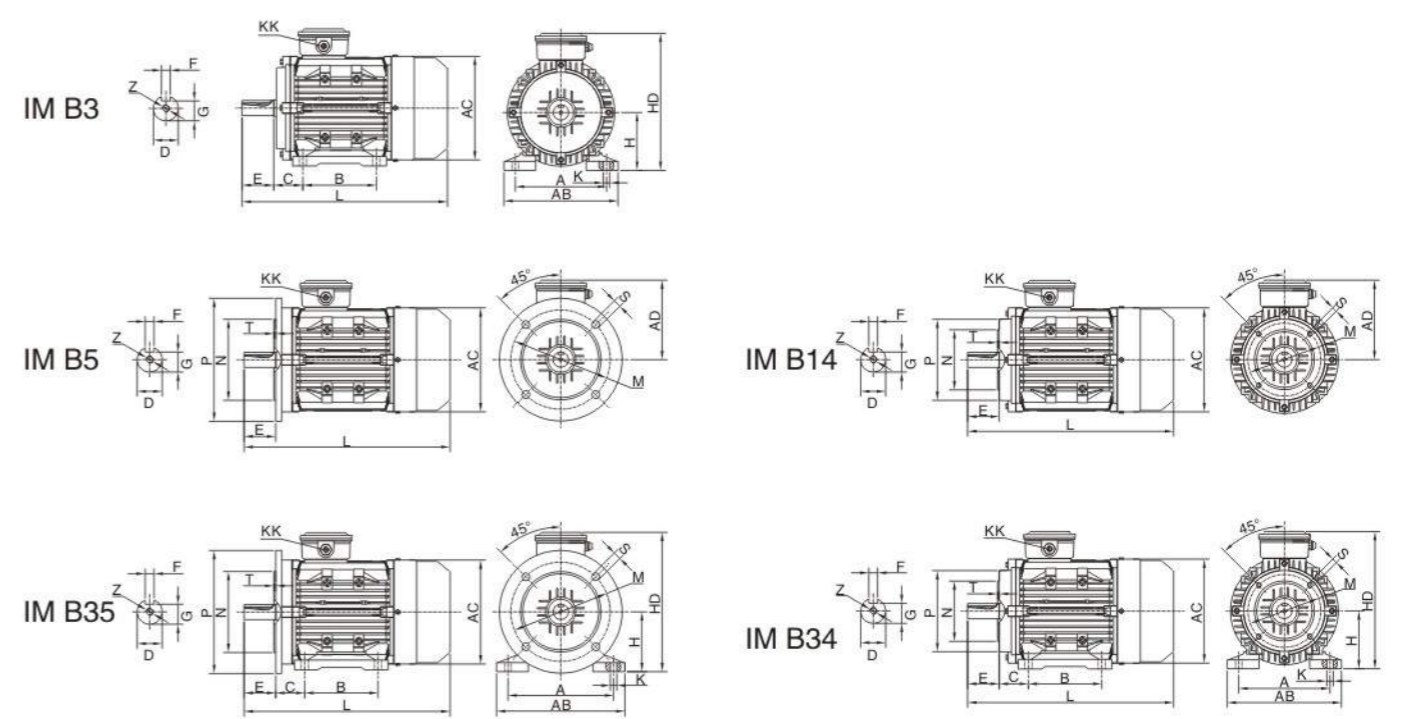

YE2/Y2铝壳B3、B5、B35电机安装及外形尺寸 Aluminium B3, B5, B35 motor instruction and overall dimension

机座号 Frame No.	安装尺寸 Mounting Dimensions															外形尺寸 Overall Dimensions							
	A	B	C	D	E	F	G	H	K	Z	KK	P	M	N	S	T	AB	AC	AD	HD	L	变频电机长度	变频电机长度
56	90	71	36	9	20	3	7.2	56	6	M4 x 12	1-M20 x 1.5	120	100	80	7	3	110	112	78	134	200		
63	100	80	40	11	23	4	8.5	63	7	M4 x 12	1-M20 x 1.5	140	115	95	9	3	125	125	100	167	230	280	295
71	112	90	45	14	30	5	11	71	7	M5 x 12	1-M20 x 1.5	160	130	110	9	3.5	140	142	110	184	260	305	317
80M	125	100	50	19	40	6	15.5	80	10	M6 x 16	1-M20 x 1.5	200	165	130	12	3.5	158	163	123	205	300	355	355
90S	140	100	56	24	50	8	20	90	10	M8 x 19	1-M20 x 1.5	200	165	130	12	3.5	175	175	130	220	310	380	377
90L	140	125	56	24	50	8	20	90	10	M8 x 19	1-M20 x 1.5	200	165	130	12	3.5	175	175	130	220	335	405	402
100L	160	140	63	28	60	8	24	100	12	M10 x 22	2-M20 x 1.5	250	215	180	15	4	200	203	157	260	380	435	435
112M	190	140	70	28	60	8	24	112	12	M10 x 22	2-M20 x 1.5	250	215	180	15	4	225	225	168	282	410	470	465
132S	216	140	89	38	80	10	33	132	12	M12 x 28	2-M20 x 1.5	300	265	230	15	4	255	268	190	323	470	540	522
132M	216	178	89	38	80	10	33	132	12	M12 x 28	2-M20 x 1.5	300	265	230	15	4	255	268	190	323	510	580	562
160M	254	210	108	42	110	12	37	160	15	M12 x 28	2-M30 x 1.5	350	300	250	19	5	315	330	240	400	605		
160L	254	254	108	42	110	12	37	160	15	M12 x 28	2-M30 x 1.5	350	300	250	19	5	315	330	240	400	650		

YE2/Y2铝壳B14、B34电机安装及外形尺寸 Aluminium B14, B34 motor instruction and overall dimension

机座号 Frame No.	安装尺寸 Mounting Dimensions															外形尺寸 Overall Dimensions							
	A	B	C	D	E	F	G	H	K	Z	KK	P	M	N	S	T	AB	AC	AD	HD	L	变频电机长度	变频电机长度
56	90	71	36	9	20	3	7.2	56	6	M4 x 12	1-M20 x 1.5	80	65	50	M5	2.5	110	112	78	134	200		
63	100	80	40	11	23	4	8.5	63	7	M4 x 12	1-M20 x 1.5	90	75	60	M5	2.5	125	125	100	167	230	280	295
71	112	90	45	14	30	5	11	71	7	M5 x 12	1-M20 x 1.5	105	85	70	M6	2.5	140	142	110	184	260	305	317
80M	125	100	50	19	40	6	15.5	80	10	M6 x 16	1-M20 x 1.5	120	100	80	M6	3	158	163	123	205	300	355	355
90S	140	100	56	24	50	8	20	90	10	M8 x 19	1-M20 x 1.5	140	115	95	M8	3	175	175	130	220	310	380	377
90L	140	125	56	24	50	8	20	90	10	M8 x 19	1-M20 x 1.5	140	115	95	M8	3	175	175	130	220	335	405	402
100L	160	140	63	28	60	8	24	100	12	M10 x 22	2-M20 x 1.5	160	130	110	M8	3.5	200	203	157	260	380	435	435
112M	190	140	70	28	60	8	24	112	12	M10 x 22	2-M20 x 1.5	160	130	110	M8	3.5	225	225	168	282	410	470	465
132S	216	140	89	38	80	10	33	132	12	M12 x 28	2-M20 x 1.5	200	165	130	M10	3.5	255	268	190	323	470	540	522
132M	216	178	89	38	80	10	33	132	12	M12 x 28	2-M20 x 1.5	200	165	130	M10	3.5	255	268	190	323	510	580	562
160M	254	210	108	42	110	12	37	160	15	M12 x 28	2-M30 x 1.5	250	215	180	M12	4	315	330	240	400	605		
160L	254	254	108	42	110	12	37	160	15	M12 x 28	2-M30 x 1.5	250	215	180	M12	4	315	330	240	400	650		

YE2/Y2方形铝壳系列电机安装及外形尺寸  
YE2/Y2 square aluminium series motor instruction and overall dimension

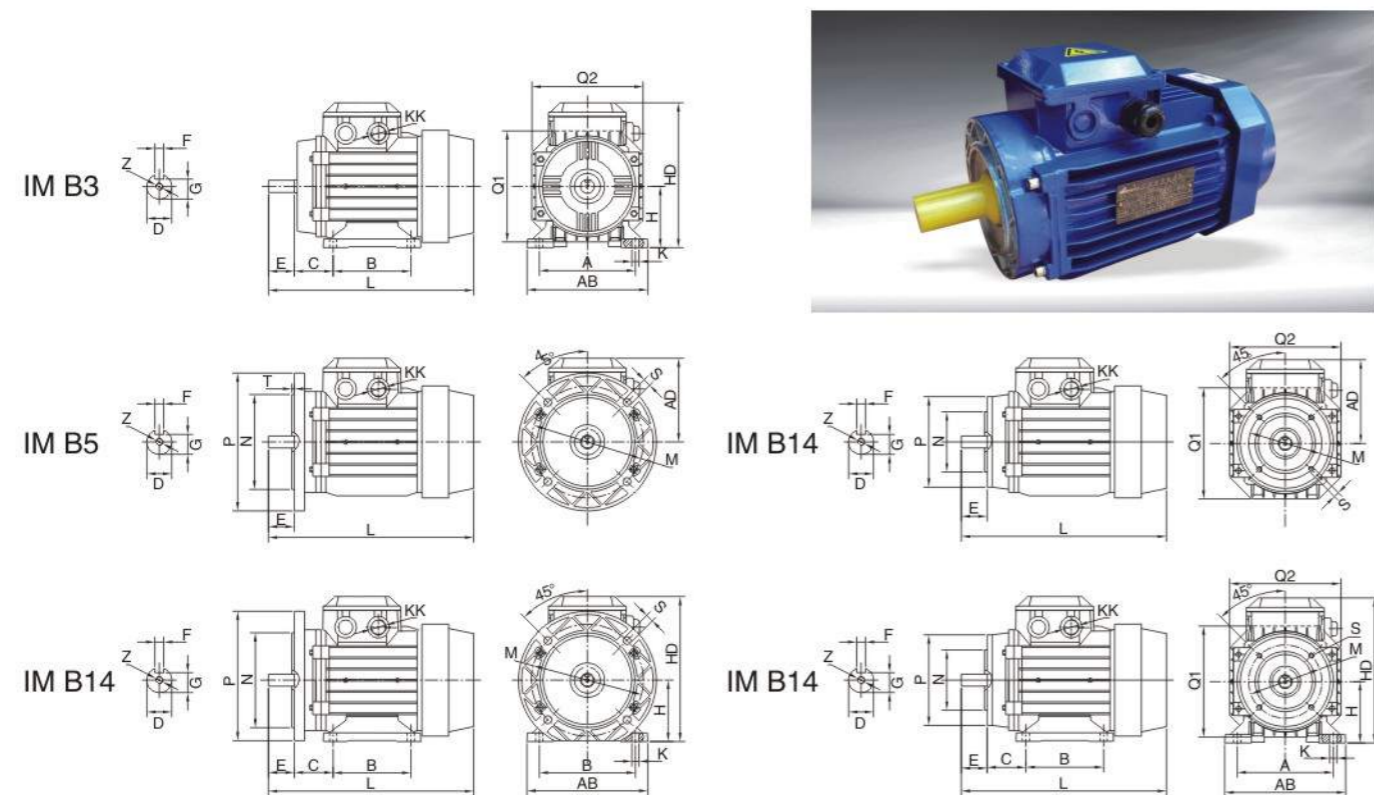

YE2/Y2铝壳B3、B5、B35电机安装及外形尺寸 Aluminium B3、B5、B35 motor instruction and overall dimension

机座号 Frame No.	安装尺寸 Mounting Dimensions															外形尺寸 Overall Dimensions						
	A	B	C	D	E	F	G	H	K	Z	KK	P	M	N	S	T	AB	AD	HD	L	Q1	Q2
56	90	71	36	9	20	3	7.2	56	6	M4x12	1-M16x1.5	120	100	80	7	3	110	92	148	190	108	108
63	100	80	40	11	23	4	8.5	63	7	M4x12	1-M16x1.5	140	115	95	9	3	125	90	153	216	116	116
71	112	90	45	14	30	5	11	71	7	M5x12	1-M18x1.5	160	130	110	9	3.5	140	100	171	241	130	130
80S	125	100	50	19	40	6	15.5	80	10	M6x16	1-M18x1.5	200	165	130	12	3.5	158	109	189	270	142	142
80L	125	100	50	19	40	6	15.5	80	10	M6x16	1-M18x1.5	200	165	130	12	3.5	158	109	189	285	142	142
90S	140	100	56	24	50	8	20	90	10	M8x19	1-M22x1.5	200	165	130	12	3.5	175	117	207	305	154	154
90L	140	125	56	24	50	8	20	90	10	M8x19	1-M22x1.5	200	165	130	12	3.5	175	117	207	325	154	154
100L	160	140	63	28	60	8	24	100	12	M10x22	2-M22x1.5	250	215	180	15	4	200	139	239	382	181	181
112M	190	140	70	28	60	8	24	112	12	M10x22	2-M25x1.5	250	215	180	15	4	225	156	268	401	204	204
132S	216	140	89	38	80	10	33	132	12	M12x28	2-M25x1.5	300	265	230	15	4	255	173	305	465	245	245
132M	216	178	89	38	80	10	33	132	12	M12x28	2-M25x1.5	300	265	230	15	4	255	173	305	521	245	245

YE2/Y2铝壳B14、B34电机安装及外形尺寸 Aluminium B14、B34 motor instruction and overall dimension

机座号 Frame No.	安装尺寸 Mounting Dimensions															外形尺寸 Overall Dimensions						
	A	B	C	D	E	F	G	H	K	Z	KK	P	M	N	S	T	AB	AD	HD	L	Q1	Q2
56	90	71	36	9	20	3	7.2	56	6	M4x12	1-M16x1.5	80	65	50	M5	2.5	110	92	148	190	108	108
63	100	80	40	11	23	4	8.5	63	7	M4x12	1-M16x1.5	90	75	60	M5	2.5	125	90	153	216	116	116
71	112	90	45	14	30	5	11	71	7	M5x12	1-M18x1.5	105	85	70	M6	2.5	140	100	171	241	130	130
80S	125	100	50	19	40	6	15.5	80	10	M6x16	1-M18x1.5	120	100	80	M6	3	158	109	189	270	142	142
80L	125	100	50	19	40	6	15.5	80	10	M6x16	1-M18x1.5	120	100	80	M6	3	158	109	189	285	142	142
90S	140	100	56	24	50	8	20	90	10	M8x19	1-M22x1.5	140	115	95	M8	3	175	117	207	305	154	154
90L	140	125	56	24	50	8	20	90	10	M8x19	1-M22x1.5	140	115	95	M8	3	175	117	207	325	154	154
100L	160	140	63	28	60	8	24	100	12	M10x22	2-M22x1.5	160	130	110	M8	3.5	200	139	239	382	181	181
112M	190	140	70	28	60	8	24	112	12	M10x22	2-M25x1.5	160	130	110	M8	3.5	225	156	268	401	204	204
132S	216	140	89	38	80	10	33	132	12	M12x28	2-M25x1.5	200	165	130	M10	3.5	255	173	305	465	245	245
132M	216	178	89	38	80	10	33	132	12	M12x28	2-M25x1.5	200	165	130	M10	3.5	255	173	305	521	245	245

Y2EJ(YEJ)系列电磁制动三相异步电动机  
Y2EJ(YEJ) Electromagnetic Breaking Three-phase Induction Motor

Y2EJ (YEJ) 系列制动电动机是全封闭自扇冷式鼠笼型具有附加圆盘型直流制动器的三相异步电动机，它具有制动迅速、结构简单、可靠性高、通用性强等优点。此外制动器具有人工释放机构，被广泛应用于各种要求快速停止和准确定位的机械设备和传动装置中。电机符合JB/T6456-1992标准，该系列电机广泛用于金属加工机床、包装机械、木工机械、食品机械、化工机械、纺织机械、建筑机械以及齿轮减速机等。

Y2EJ(YEJ) series braking motors are total enclosed fan cool squirrel-cage tri phase induction motors, it have an append braking disc, by dc power. fast braking, simple structure, high stability. the brake has a handed release structure, wide applied to any transmission that need rapid stop, exact positioning. the motors according with standard JB/T6456-1992, this motors wide applied to lathe machine wood machine food processing equipment chem engineering packing machine textile machine architectural machine gear reducer etc.

使用条件  
环境温度:  $-15^{\circ}\text{C} \leq \theta \leq 40^{\circ}\text{C}$   
海拔: 不超过1000米  
电压: 380V  
频率: 50Hz、60Hz  
接法: 3kW及以下规格Y接法,  
3kW以上规格为 $\Delta$ 接法  
绝缘等级: B、F  
防护等级: IP44、IP54、IP55

Operating Condition  
Ambient temperature:  $-15^{\circ}\text{C} \leq \theta \leq 40^{\circ}\text{C}$   
Altitude: Not exceed 1000m  
Voltage: 380V  
Frequency: 50Hz, 60Hz  
Connection: Y Start-connection for 3kw and below,  
 $\Delta$ Delta-connection for 3kw or more  
Insulation class: B, F  
Grade protection: IP44, IP54, IP55



Y2EJ铁壳系列电磁制动电机安装及外形尺寸  
Y2EJ cast iron series electromagnetic braking motor instruction and overall dimension

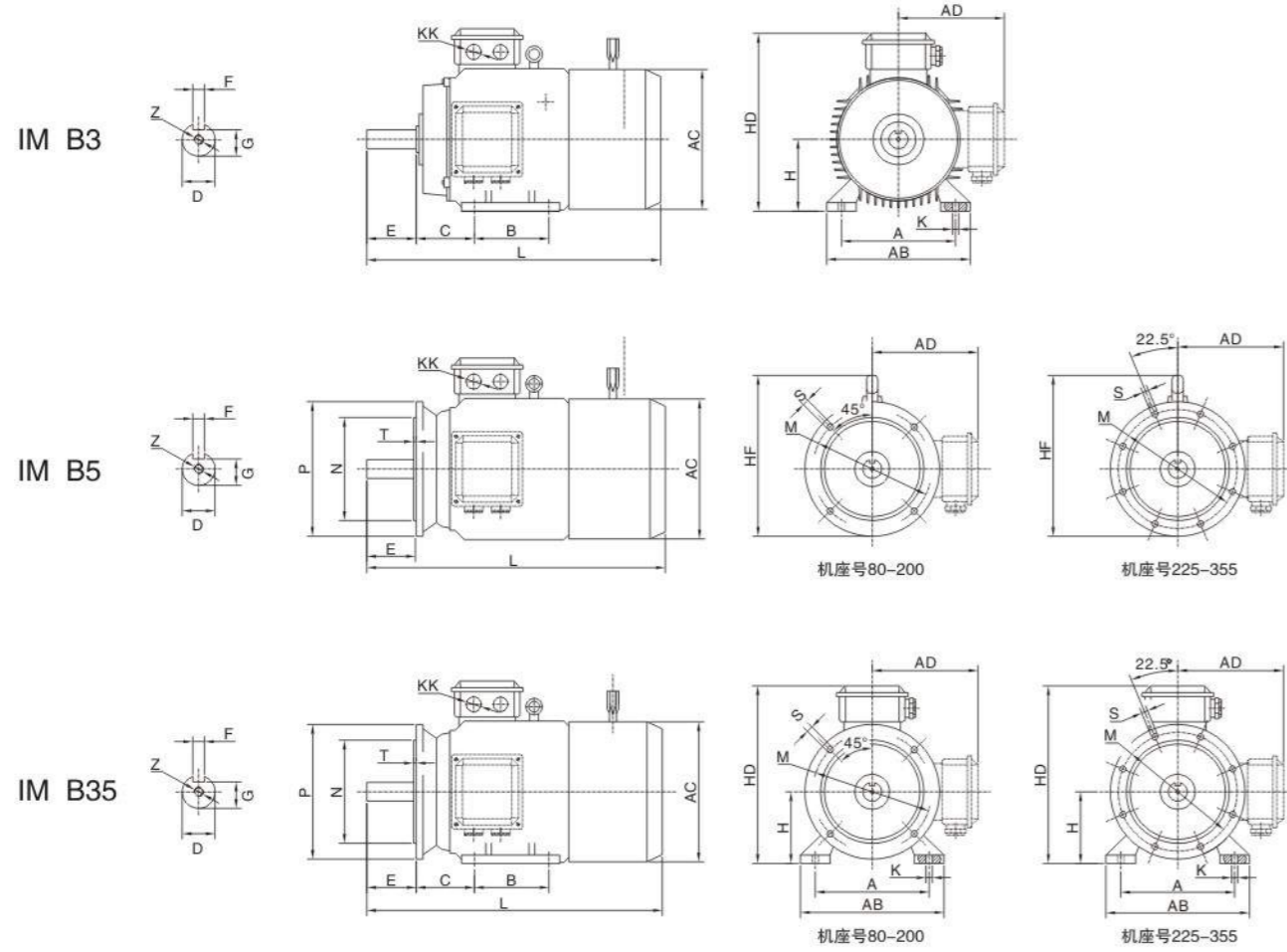

机座号 Frame No.	安装尺寸 Mounting Dimensions											外形尺寸 Overall Dimensions										
	A	B	C	D	E	F	G	H	K	Z	KK	P	M	N	S	T	AB	AC	AD	HD	HF	L
63	100	80	40	11	23	4	8.5	63	7	M4 x 12	1-M20 x 1.5	140	115	95	9	3	135	130	70	180	130	260
71	112	90	45	14	30	5	11	71	7	M5 x 12	1-M20 x 1.5	160	130	110	9	3.5	150	145	80	195	145	385
80M	125	100	50	19	40	6	15.5	80	10	M6 x 16	1-M20 x 1.5	200	165	130	12	3.5	165	175	145	220	185	340
90S	140	100	56	24	50	8	20	90	10	M8 x 19	1-M20 x 1.5	200	165	130	12	3.5	180	195	155	250	195	380
90L	140	125	56	24	50	8	20	90	10	M8 x 19	1-M20 x 1.5	200	165	130	12	3.5	180	195	155	250	195	405
100L	160	140	63	28	60	8	24	100	12	M10 x 22	1-M20 x 1.5	250	215	180	15	4	205	215	180	270	245	440
112M	190	140	70	28	60	8	24	112	12	M10 x 22	2-M25 x 1.5	250	215	180	15	4	230	240	190	300	265	470
132S	216	140	89	38	80	10	33	132	12	M12 x 28	2-M25 x 1.5	300	265	230	15	4	270	275	210	345	315	550
132M	216	178	89	38	80	10	33	132	12	M12 x 28	2-M25 x 1.5	300	265	230	15	4	270	275	210	345	315	580
160M	254	210	108	42	110	12	37	160	15	M12 x 28	2-M25 x 1.5	350	300	250	19	5	320	330	255	420	385	605
160L	254	254	108	42	110	12	37	160	15	M12 x 28	2-M25 x 1.5	350	300	250	19	5	320	330	255	420	385	650
180M	279	241	121	48	110	14	42.5	180	15	M12 x 28	2-M25 x 1.5	350	300	250	19	5	355	380	280	455	430	700
180L	279	279	121	48	110	14	42.5	180	15	M12 x 28	2-M25 x 1.5	350	300	250	19	5	355	380	280	455	430	735
200L	318	305	133	55	110	16	49	200	19	M20 x 42	2-M50 x 1.5	400	350	300	19	5	395	420	305	505	480	780
225S(4-8P)	356	286	149	60	140	18	53	225	19	M20 x 42	2-M50 x 1.5	450	400	350	19	5	435	470	335	560	530	820
225M(2P)	356	311	149	55	110	16	49	225	19	M20 x 42	2-M50 x 1.5	450	400	350	19	5	435	470	335	560	530	845
225M(4-8P)	356	311	149	60	140	18	53	225	19	M20 x 42	2-M50 x 1.5	450	400	350	19	5	435	470	335	560	530	875

Y2EJ(YEJ)系列技术参数 Technical data

2极 Pole

电机型号 Type	额定功率 Power	转速 Speed	额定电流 Amps	效率 Eff.	功率因数 Power factor	制动扭矩 Braking torque	制动时间 Braking time	Energizing Power	Ist/In	Tst/TN	Tmax/Tn	重量 Weight
	KW	RPM	A	%	Cos Φ	N.m	S					
380V/50HZ 2POLE 3000RPM												
Y2EJ 63M1	0.18	2720	0.53	65	0.8	4	0.2	18	5.5	2.2	2.2	12
Y2EJ 63M1	0.25	2720	0.69	68	0.81	4	0.2	18	5.5	2.2	2.2	13
Y2EJ 71M1	0.37	2740	0.99	70	0.81	4	0.2	18	6.1	2.2	2.2	14
Y2EJ 71M2	0.55	2740	1.4	73	0.82	4	0.2	18	6.1	2.2	2.2	15
Y2EJ 80 M1	0.75	2845	1.83	75	0.83	7.5	0.2	30	6.1	2.2	2.3	17
Y2EJ 80M2	1.1	2840	2.58	77	0.84	7.5	0.2	30	7	2.2	2.3	18
Y2EJ 90S	1.5	2840	3.43	79	0.84	15	0.2	50	7	2.2	2.3	23
Y2EJ 90L	2.2	2840	4.85	81	0.85	15	0.2	50	7	2.2	2.3	26
Y2EJ 100L	3	2860	6.31	83	0.87	30	0.2	65	7.5	2.2	2.3	37
Y2EJ 112M	4	2880	8.1	85	0.88	40	0.25	90	7.5	2.2	2.3	45
Y2EJ 132S1	5.5	2900	11	86	0.88	75	0.25	90	7.5	2.2	2.3	69
Y2EJ 132S2	7.5	2900	14.9	87	0.88	75	0.25	90	7.5	2.2	2.3	72
Y2EJ 160M1	11	2930	21.3	88	0.89	150	0.35	150	7.5	2.2	2.3	120
Y2EJ 160M2	15	2930	28.8	89	0.89	150	0.35	150	7.5	2.2	2.3	130
Y2EJ 160L	18.5	2930	34.7	90	0.9	150	0.35	150	7.5	2.2	2.3	149
Y2EJ 180M	22	2940	40.8	91	0.9	200	0.35	150	7.5	2	2.3	189
Y2EJ 200L1	30	2950	55.5	91.6	0.9	300	0.45	200	7.5	2	2.3	243
Y2EJ 200L2	37	2950	67.6	92.4	0.9	300	0.45	200	7.5	2	2.3	267
Y2EJ 22.5M	45	2970	82	92.7	0.9	400	0.45	200	7.5	2	2.3	323

4极 Pole

电机型号 Type	额定功率 Power	转速 Speed	额定电流 Amps	效率 Eff.	功率因数 Power factor	制动扭矩 Braking torque	制动时间 Braking time	Energizing Power	Ist/In	Tst/TN	Tmax/Tn	重量 Weight
	KW	RPM	A	%	Cos Φ	N.m	S					
380V/50HZ 4POLE 1500RPM												
Y2EJ 63M1	0.12	1310	0.44	57	0.72	4	0.2	18	4.4	2.1	2.2	13
Y2EJ 63M2	0.18	1310	0.62	60	0.73	4	0.2	18	4.4	2.1	2.2	14
Y2EJ 71M1	0.25	1330	0.79	65	0.74	4	0.2	18	5.2	2.1	2.2	15
Y2EJ 71M2	0.37	1330	1.12	67	0.75	4	0.2	18	5.2	2.1	2.2	16
Y2EJ 80M1	0.55	1390	1.57	71	0.75	7.5	0.2	30	5.2	2.4	2.2	17
Y2EJ 80M2	0.75	1390	2.03	73	0.76	7.5	0.2	30	6	2.3	2.3	18
Y2EJ 90S	1.1	1380	2.89	75	0.77	15	0.2	50	6	2.3	2.3	22
Y2EJ 90L	1.5	1390	3.07	78	0.79	15	0.2	50	6	2.3	2.3	27
Y2EJ 100L	2.2	1390	5.16	80	0.81	30	0.2	65	7	2.3	2.3	34
Y2EJ 100L2	3	1410	6.78	82	0.82	30	0.2	65	7	2.3	2.3	38
Y2EJ 112M	4	1410	8.8	84	0.82	40	0.25	90	7	2.3	2.3	48
Y2EJ 132S	5.5	1435	11.7	85	0.83	75	0.25	90	7	2.3	2.3	71
Y2EJ 132M	7.5	1440	15.6	87	0.84	75	0.25	150	7	2.3	2.3	83
Y2EJ 160M	11	1440	22.3	88	0.84	150	0.35	150	7	2.2	2.3	128
Y2EJ 160L	15	1460	30.1	89	0.85	150	0.35	150	7	2.2	2.3	142
Y2EJ 180M	18.5	1470	35.9	91	0.86	200	0.35	150	8	2.2	2.3	184
Y2EJ 180L	22	1470	42.6	91.3	0.86	200	0.35	150	8	2.2	2.3	197
Y2EJ 200L	30	1470	57.4	92.4	0.86	300	0.45	200	7	2.2	2.3	264
Y2EJ 225S	37	1480	69.6	92.9	0.87	300	0.45	200	7	2.2	2.3	303
Y2EJ 225M	45	1480	84.3	93.3	0.87	400	0.45	200	7	2.2	2.3	337

Y2EJ(YEJ)系列技术参数 Echnical data

6极 Pole

电机型号 Type	额定功率 Power	转速 Speed	额定电流 Amps	效率 Eff.	功率因数 Power factor	制动扭矩 Braking torque	制动时间 Braking time	Energizing Power	Ist/In	Tst/TN	Tmax/Tn	重量 Weight
	KW	RPM	A	%	Cos Φ	N.m	S	W				KG
380V/50HZ 6POLE 1000RPM												
Y2EJ 71M1	0.18	850	0.74	56	0.68	4	0.2	18	4	1.9	2	9.5
Y2EJ 71M2	0.25	850	0.95	59	0.68	4	0.2	18	4	1.9	2	11
Y2EJ 80M1	0.37	885	1.3	62	0.7	7.5	0.2	30	4.7	1.9	2	17
Y2EJ 80M2	0.55	885	1.79	65	0.72	7.5	0.2	30	4.7	1.9	2.1	19
Y2EJ 90S	0.75	910	2.29	69	0.72	15	0.2	50	5.5	2	2.1	22
Y2EJ 90L	1.1	910	3.18	72	0.73	15	0.2	50	5.5	2	2.1	26
Y2EJ 100L	1.5	920	3.94	76	0.75	30	0.2	65	6.5	2	2.1	34
Y2EJ 112M	2.2	935	5.6	79	0.76	40	0.25	90	6.5	2	2.1	42
Y2EJ 132S	3	960	7.4	81	0.76	75	0.25	90	8.5	2.1	2.1	68
Y2EJ 132M1	4	960	9.8	82	0.76	75	0.25	90	6.5	2.1	2.1	79
Y2EJ 132M2	5.5	960	12.9	84	0.77	75	0.25	90	6.5	2.1	2.1	87
Y2EJ 160M	7.5	970	17	86	0.77	150	0.35	150	6.5	2	2.1	122
Y2EJ 160L	11	970	24.2	87	0.78	150	0.35	150	6.5	2	2.1	141
Y2EJ 180L	15	979	31.5	89.2	0.81	200	0.35	150	7	2	2.1	195
Y2EJ 200L1	18.5	970	38.4	90.3	0.81	300	0.45	200	7	2.1	2.1	217
Y2EJ 200L2	22	970	44.5	90.4	0.83	300	0.45	200	7	2.2	2.1	240
Y2EJ 225M	30	980	59.1	91.8	0.84	400	0.45	200	7	2	2.1	323

8极 Pole

电机型号 Type	额定功率 Power	转速 Speed	额定电流 Amps	效率 Eff.	功率因数 Power factor	制动扭矩 Braking torque	制动时间 Braking time	Energizing Power	Ist/In	Tst/TN	Tmax/Tn	重量 Weight
	KW	RPM	A	%	Cos Φ	N.m	S	W				KG
380V/50HZ 8POLE 750RPM												
YEJ 80M1	0.18	645	0.88	51	0.61	7.5	0.2	30	3.3	1.8	1.9	17
YEJ 80M2	0.25	645	1.15	54	0.61	7.5	0.2	50	3.3	1.8	1.9	19
YEJ 90S	0.37	670	1.49	62	0.61	15	0.2	50	4	1.8	1.9	23
YEJ 90L	0.55	670	2.18	63	0.61	15	0.2	50	4	1.8	2	25
YEJ 100L1	0.75	680	2.17	71	0.67	30	0.2	65	4	1.8	2	33
YEJ 100L2	1.1	680	2.39	73	0.69	30	0.2	65	5	1.8	2	38
YEJ 112M	1.5	690	4.5	75	0.69	40	0.25	90	5	1.8	2	50
YEJ 132S	2.2	705	6	78	0.71	75	0.25	90	6	1.8	2	63
YEJ 132M	3	705	7.9	79	0.73	75	0.25	90	6	1.8	2	79
YEJ 160M1	4	720	10.3	81	0.73	150	0.35	150	6	1.9	2	118
YEJ 160M2	5.5	720	13.6	83	0.74	150	0.35	150	6	2	2	119
YEJ 160L	7.5	720	17.8	85.5	0.75	150	0.35	150	6	2	2	145
YEJ 180L	11	730	25.1	87.8	0.76	300	0.35	150	6.6	2	2	193
YEJ 200L	15	730	34	88.3	0.76	300	0.45	200	6.6	2	2	250
YEJ 225S	18.5	730	40.9	90.4	0.76	300	0.45	200	6.6	1.9	2	261
YEJ 225M	22	740	47.1	91	0.78	150	0.45	200	6.6	1.9	2	283

YVF2(YVP)系列变频调速三相异步电动机  
YVF2(YVP) series Variable Frequency Adjustable Speed  
Three-phase Induction Motors

YVF2 (YVP)系列电动机吸取了国外先进国家产品的技术,应用CAD设计。频率在5(3)~50Hz范围内作恒转矩调速运行且运行平稳,无转矩脉动现象,并具有较高的起动转矩和较小的起动电流。频率在50~100Hz范围内能输出恒功率特性。本系列电动机调速范围宽、振动小、噪声低、能与国内外各种SPWM变频装置相配套,构成交流变频无级调速系统。YVF2 (YVP)系列电动机的功率等级与安装尺寸、机座中心高均符合国际IEC标准,其对应关系与Y2系列三相异步电动机相一致,互换性通用性强。本系统电动机为笼型结构、运行可靠、维修方便,并装有独立的冷却风机、保证电机在不同的转速下、均具有较好的冷却效果。

YVF2 (YVP)系列变频调速电动机与SPWM变频装置构成的调速系统与其他调速方式相比,具有节能效果明显、调速性能好、调速比宽、快速响应性优良、应用范围广、性能价格比高等优点,是目前交流调速方案中最先进的系统之一。可广泛用于数控机床的主轴传动、纺织、化工、冶金等行业的恒转矩、恒功率调速以及风机水泵等场合的节能调速,并具有计算机控制接口,有助于实现调速系统的自动化控制、是国家目前重点推广的高新技术节能产品。

YVF2(YVP) series motor have incorporated the advanced technology abroad and use CAD technique to design motors. There fore, at low speed (Frequency 5-50Hz)for constant torque speed running and stable operation, without torque oscillation, and has a larger starting torque and a smaller starting current. Frequency (50-100Hz)can output internal energy of constant power. The motor possesses a wide range for speed governing, little vibration and low noise, can match with a variety of SPWM converter at home and abroad, to comprise an alternating stepless converter control system. Its power class, mounting dimensions and center height of bedplate are all according to IEC standards and Y2 series three phase asynchronous motor. Also its interchangeability and versatility are good. The structure of the motor is cage squirrel, high reliability and easy maintenance. And equipped with independent cooling fan, under different rotational speed of motor, the motor can keep good cooling effect.

When compared to other speed governing methods, the speed governing system constituted by YVF2(YVP) converter control motor and the SPWM converter has remarkable energy-saving effects, good speed control performance, wide speed control ratios excellent response; a wide application range, high performance-cost ratio, etc, which is one of the most advanced alternating-current speed governing system. It can be used in the main spindle transmission of NC tool machines, for constant torque and power speed control in the textile, chemistry, metal Industry etc. and energy-saving speed control for fan and water pumps. Furthermore, it has computer interfaces, and can carry out automatic control of the speed governing system. In general, it is one of high new technical energy-saving products.



YVF2(YVP)系列变频调速三相异步电动机  
YVF2(YVP) series variable frequency adjustable speed three-phase induction motors

使用条件  
环境温度: -15 ~ +40°C  
使用环境: 海拔不超过1000m  
防护等级: IP44  
电压: 380 (220) V ± 10%  
频率: 50 (60) Hz ± 2%  
工作制: S1连续  
绝缘: F  
接法: 3KW及以下电机, 使用220V变频器时请改为△接法。  
冷却方式: IC 0141

Operating Conditions  
Ambient temperature: -15 ~ +40°C  
Altitude: Not exceed 1000m  
Protection: IP44  
Voltage: 380 (220)V ± 10%  
Frequency: 50 (60)Hz ± 2%  
Duty: S1  
Insulation: F  
Connection: For 3kw of smaller motor if a 220v converter is used.  
The△connection is necessary  
Cooling method: IC 0141

YVF2(YVP)系列技术参数 Technical Data

电机型号 Type	功率 Power (Kw)	电流 Amps (A)	额定转矩 Rated torque (N.m)	恒转矩变频范围 Frequency at constant Torque (Hz)	恒功率调频范围 Frequency at constant Power (Hz)	堵转转矩 额定转矩 Tstart / Tn	堵转电流 额定电流 Ist / In	最大转矩 额定转矩 Tmax / Tn	最小转矩 额定转矩 Tmin / Tn
YVF2-80M1-4	0.55	1.5	3.5	5-50	50-100	2	10	2.8	1.7
YVF2-80M2-4	0.75	2	4.7	5-50	50-100	2	10	2.8	1.6
YVF2-90S-4	1.1	2.8	7	5-50	50-100	2	10	2.8	1.6
YVF2-90L-4	1.5	3.7	9.5	5-50	50-100	2	10	2.8	1.6
YVF2-100L1-4	2.2	5.1	14	5-50	50-100	2	10	2.8	1.5
YVF2-100L2-4	3	6.8	19	5-50	50-100	2	10	2.8	1.5
YVF2-112M-4	4	8.7	25.4	5-50	50-100	2	10	2.81	1.5
YVF2-132S-4	5.5	11.4	35	5-50	50-100	2	10	2.8	1.4
YVF2-132M-4	7.5	15.3	47.7	5-50	50-100	2	10	2.8	1.4
YVF2-160M-4	1.1	22.1	70	5-50	50-100	2	10	2.8	1.4
YVF2-160L-4	15	30.1	95.5	5-50	50-100	2	10	2.8	1.4
YVF2-180M-4	18.5	35.4	117.1	5-50	50-100	2	10	2.8	1.2
YVF2-180L-4	22	41.6	140.9	5-50	50-100	2	10	2.8	1.2
YVF2-200L-4	30	55.9	190.9	5-50	50-100	2	10	2.8	1.2
YVF2-225S-4	37	68.2	235.5	5-50	50-100	2	10	2.8	1.2
YVF2-225M-4	45	82.5	286.4	5-50	50-100	2	10	2.8	1.1
YVF2-250M-4	55	101	350.1	3-50	50-100	1.7	10	2.8	1.1
YVF2-280S-4	75	132.3	477.1	3-50	50-100	1.7	10	2.8	1
YVF2-280M-4	90	157.4	572.9	3-50	50-100	1.7	10	2.8	1
YVF2-315S-4	110	191.4	700.0	3-50	50-100	1.7	10	2.8	1
YVF2-315M-4	132	227.6	840.3	3-50	50-100	1.7	10	2.8	1
YVF2-315L1-4	160	274.2	1018.5	3-50	50-100	1.7	10	2.8	1
YVF2-315L2-4	200	341.6	1273.2	3-50	50-100	1.7	10	2.8	0.9

YVF2(YVP)铁壳系列变频调速电机安装及外形尺寸  
YVF2(YVP) Cast iron series variable frequency adjustable speed motor instruction and overall dimension

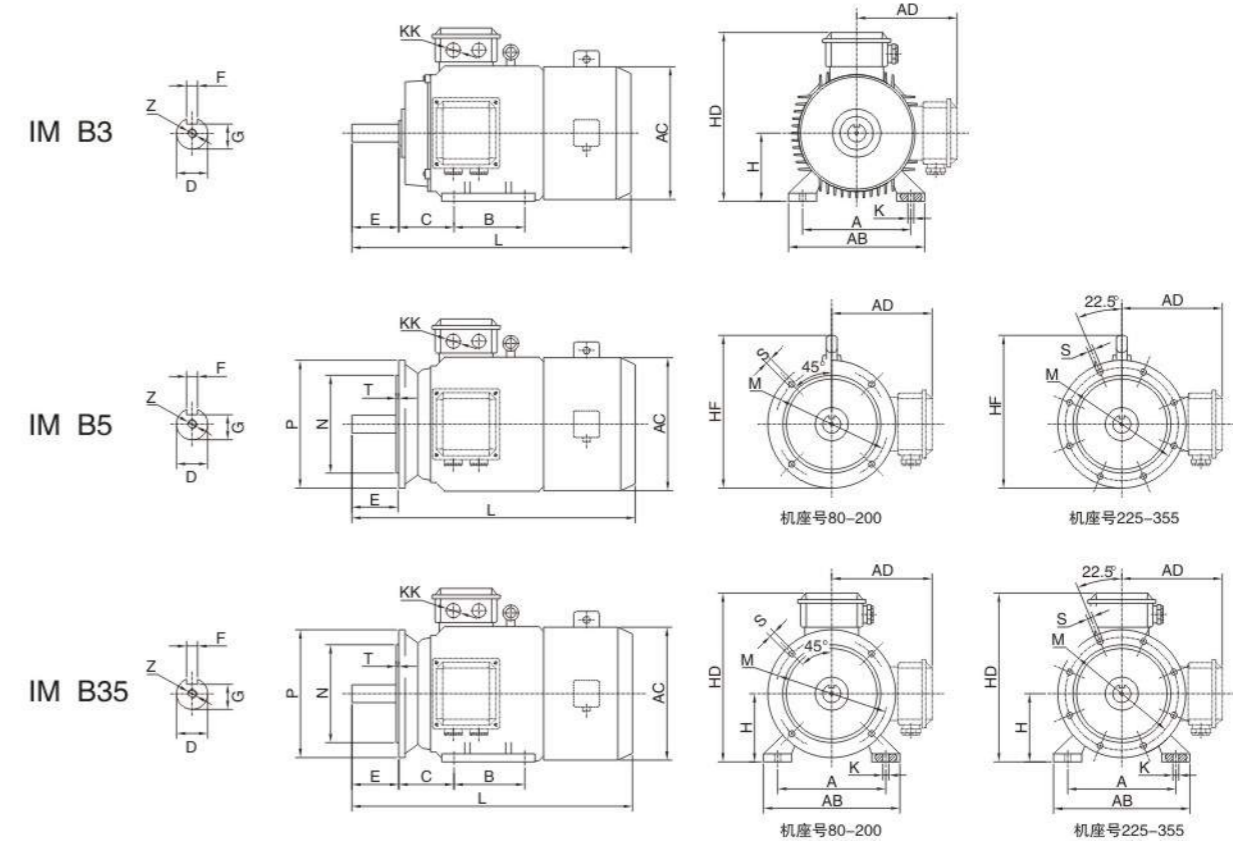

机座号 Frame No.	安装尺寸 Mounting Dimensions															外形尺寸 Overall Dimensions						
	A	B	C	D	E	F	G	H	K	Z	KK	P	M	N	S	T	AB	AC	AD	HD	HF	L
80M	125	100	50	19	40	6	15.5	80	10	M6 × 16	1-M20 × 1.5	200	165	130	12	3.5	165	175	145	220	185	355
90S	140	100	56	24	50	8	20	90	10	M8 × 19	1-M20 × 1.5	200	165	130	12	3.5	180	195	155	250	195	400
90L	140	125	56	24	50	8	20	90	10	M8 × 19	1-M20 × 1.5	200	165	130	12	3.5	180	195	155	250	195	430
100L	160	140	63	28	60	8	24	100	12	M10 × 22	1-M20 × 1.5	250	215	180	15	4	205	215	180	270	245	465
112M	190	140	70	28	60	8	24	112	12	M10 × 22	2-M25 × 1.5	250	215	180	15	4	230	240	190	300	265	490
132S	216	140	89	38	80	10	33	132	12	M12 × 28	2-M25 × 1.5	300	265	230	15	4	270	275	210	345	315	525
132M	216	178	89	38	80	10	33	132	12	M12 × 28	2-M25 × 1.5	300	265	230	15	4	270	275	210	345	315	575
160M	254	210	108	42	110	12	37	160	15	M12 × 28	2-M25 × 1.5	350	300	250	19	5	320	330	255	420	385	645
160L	254	254	108	42	110	12	37	160	15	M12 × 28	2-M25 × 1.5	350	300	250	19	5	320	330	255	420	385	690
180M	279	241	121	48	110	14	42.5	180	15	M12 × 28	2-M25 × 1.5	350	300	250	19	5	355	380	280	455	430	810
180L	279	279	121	48	110	14	42.5	180	15	M12 × 28	2-M25 × 1.5	350	300	250	19	5	355	380	280	455	430	850
200L	318	305	133	55	110	16	49	200	19	M20 × 42	2-M50 × 1.5	400	350	300	19	5	395	420	305	505	480	890
225S	356	286	149	60	140	18	53	225	19	M20 × 42	2-M50 × 1.5	450	400	350	19	5	435	470	335	560	530	930
225M	356	311	149	60	140	18	53	225	19	M20 × 42	2-M50 × 1.5	450	400	350	19	5	435	470	335	560	530	970
250M	406	349	168	65	140	18	58	250	24	M20 × 42	2-M50 × 1.5	550	500	450	19	5	490	510	370	615	595	1050
280S	457	368	190	75	140	20	67.5	280	24	M20 × 42	2-M63 × 1.5	550	500	450	19	5	550	580	410	680	650	1100
280M	457	419	190	75	140	20	67.5	280	24	M20 × 42	2-M63 × 1.5	550	500	450	19	5	550	580	410	680	650	1180
315S	508	406	216	80	170	22	71	315	28	M20 × 42	2-M63 × 1.5	660	600	550	24	6	635	645	530	845		1300
315M	508	457	216	80	170	22	71	315	28	M20 × 42	2-M63 × 1.5	660	600	550	24	6	635	645	530	845		1350
315L	508	508	216	80	170	22	71	315	28	M20 × 42	2-M63 × 1.5	660	600	550	24	6	635	645	530	845		1450
355M	610	560	254	95	170	25	86	355	28	M20 × 42	2-M63 × 1.5	800	740	680	24	6	730	710	655	1010		1650
355L	610	630	254	95	170	25	86	355	28	M20 × 42	2-M63 × 1.5	800	740	680	24	6	730	710	655	1010		1750

## YD系列变级多速三相异步电动机 YD series Three Phase Multispeed Induction Motor

该系列结合世界先进同类产品的优点设计生产，完全符合IEC国际标准。结构安装尺寸同Y、Y2系列电机相同。该电机采用变极数的方式来实现速度调整。该系列电动机具有体积小、重量轻、噪音低、启动性能好、运行可靠、维护方便的特点。主要技术指数达到国际技术标准。

该系列电动机广泛用于需要逐级调整速度的各种机械设备，能使设备结构紧凑、噪音低并达到节能的目的。

同时，特殊型号的变速电动机，例如适用于YD系列风机和水泵的变速三相异步电动机，能根据用户要求设计制造。防护等级：IP44、IP54、IP55；电压：380V、400V、415V、440V；频率：50Hz、60Hz。

This series motors are designed and manufactured under incorporating the advantages of the counterparts in the world, and are in full conformity with international standard of IEC. This motor employs method of changing the pole numbers so as to carry out speed adjustment. The series motors have features of small volume, light weight, low noise, well starting performance, reliable operation, convenient maintenance, etc. The main technical indexes have reached the international standard.

The series motors are widely used in various mechanical equipment which needs stepped speed adjustment, so that they enable the equipment to have compact structure, lower noise and ability to save energy.

Simultaneously, multi-speed motor with special specification can be designed and manufactured according to the requirements of customers, such as multi-speed three-phase asynchronous motor for YD fans and pumps. Degree of protection: IP44, IP54, IP55 Rated voltage: 380V, 400V, 415V, 440V; Rated voltage: 380V, 400V, 415V, 440V; Rated frequency: 50Hz, 60Hz.



### YD系列技术参数 Technical data

电机型号 Type	极数 Poles	输出功率 Output KW	额定电流 Rated current (A)			转速 Speed RPM	效率 Efficiency %	功率因数 Power factor Cos Φ	堵转转矩 额定转矩 Ts/Tn	堵转电流 额定电流 Is/In	最大转矩 额定转矩 Tmax/Tn
			380V	400V	415V						
2/4极Pole											
YD80K	4	0.45	1.4	1.3	1.3	1420	66	0.74	1.5	6.5	1.8
	2	0.55	1.5	1.4	1.4	2860	65	0.85	1.6	7	1.8
YD80G	4	0.55	1.7	1.6	1.6	1420	68	0.74	1.5	6.5	1.8
	2	0.75	2	1.9	1.8	2860	66	0.85	1.6	7	1.8
YD90S	4	0.85	2.3	2.2	2.1	1430	74	0.77	1.5	6.5	1.8
	2	1.1	2.8	2.7	2.6	2850	72	0.84	1.6	7	1.8
YD90L	4	1.3	3.3	3.1	3.0	1430	76	0.78	1.5	6.5	1.8
	2	1.8	4.3	4.1	3.9	2850	74	0.84	1.6	7	1.8
YD100LA	4	2	4.8	4.6	4.4	1430	78	0.81	1.5	6.5	1.8
	2	2.4	5.6	5.3	5.1	2850	76	0.86	1.6	7	1.8
YD100LB	4	2.4	5.6	5.3	5.1	1430	79	0.83	1.5	6.5	1.8
	2	3	5.7	5.4	5.2	2850	77	0.89	1.6	7	1.8
YD112L	4	3.3	7.4	7.0	6.8	1450	81	0.83	1.5	6.5	1.8
	2	4	8.6	8.2	7.9	2860	80	0.88	1.6	7	1.8
YD132S	4	4.5	9.8	9.3	9.0	1450	83	0.84	1.5	6.5	1.8
	2	5.5	11.9	11.3	10.9	2860	79	0.88	1.6	7	1.8
YD132M	4	6.5	13.8	13.1	12.6	1450	84	0.85	1.5	6.5	1.8
	2	8	17.1	16.2	15.7	2880	80	0.89	1.6	7	1.8
YD160M	4	9	18.5	17.6	16.9	1460	87	0.85	1.5	6.5	1.8
	2	11	22.9	21.8	21.0	2920	82	0.89	1.6	7	1.8
YD160L	4	11	22.3	21.2	20.4	1460	87	0.86	1.5	6.5	1.8
	2	14	28.8	27.4	26.4	2920	82	0.9	1.6	7	1.8
YD180M	4	15	29.4	27.9	26.9	1470	89	0.87	1.5	6.5	1.8
	2	18.5	36.7	34.9	33.6	2940	85	0.9	1.6	7	1.8
YD180L	4	18.5	35.9	34.1	32.9	1470	89	0.88	1.5	6.5	1.8
	2	22	42.7	40.6	39.1	2940	86	0.91	1.6	7	1.8
YD200L	4	26	49.9	47.4	45.7	1470	89	0.89	1.4	6.5	1.8
	2	30	58.3	55.4	53.4	2950	85	0.92	1.4	7	1.8
YD225S	4	32	60.7	57.7	55.6	1480	90	0.89	1.4	6.5	1.8
	2	37	71.7	68.1	65.7	2960	86	0.92	1.4	7	1.8
YD225M	4	37	69.4	65.9	63.5	1480	91	0.89	1.4	6.5	1.8
	2	45	86.4	82.1	79.1	2960	87	0.92	1.4	7	1.8
YD250M	4	45	84.4	80.2	77.3	1480	91	0.89	1.4	6.5	1.8
	2	55	103.2	98.0	94.5	2960	88	0.92	1.4	7	1.8
YD280S	4	60	111.3	105.7	101.9	1480	91	0.9	1.4	6.5	1.8
	2	72	135.1	128.3	123.7	2970	88	0.92	1.4	7	1.8
YD280M	4	72	133.6	126.9	122.3	1480	91	0.9	1.4	6.5	1.8
	2	82	152.2	144.6	139.4	2970	88	0.93	1.4	7	1.8
4/6极Pole											
YD90S	6	0.65	2.2	2.1	2.0	920	64	0.7	1.4	6.5	1.8
	4	0.85	2.3	2.2	2.1	1420	70	0.79	1.3	7	1.8
YD90L	6	0.85	2.8	2.7	2.6	930	66	0.7	1.4	6.5	1.8
	4	1.1	3	2.9	2.7	1420	71	0.79	1.3	7	1.8

YD系列技术参数 Technical data

电机型号 Type	极数 Poles	输出功率 Output KW	额定电流 Rated current (A)			转速 Speed RPM	效率 Efficiency %	功率因数 Power factor Cos Φ	堵转转矩 额定转矩 Ts/Tn	堵转电流 额定电流 Is/In	最大转矩 额定转矩 Tmax/Tn
			380V	400V	415V						
4/6极Pole											
YD100LA	6	1.3	3.8	3.6	3.5	940	74	0.7	1.4	6	1.8
	4	1.8	4.4	4.2	4.0	1440	77	0.8	1.3	6.5	1.8
YD100LB	6	1.5	4.3	4.1	3.9	940	75	0.7	1.4	6	1.8
	4	2.2	5.4	5.1	4.9	1440	77	0.8	1.3	6.5	1.8
YD112M	6	2.2	5.7	5.4	5.2	960	77	0.75	1.4	6	1.8
	4	2.8	6.7	6.4	6.1	1440	77	0.82	1.3	6.5	1.8
YD132S	6	3	7.7	7.3	7.1	960	79	0.75	1.4	6	1.8
	4	4	9.5	9.0	8.7	1440	80	0.82	1.3	6.5	1.8
YD132M	6	4	9.8	9.3	9.0	960	81	0.76	1.4	6	1.8
	4	5.5	12.3	11.7	11.3	1440	80	0.85	1.3	6.5	1.8
YD160M	6	6.5	15.1	14.3	13.8	970	84	0.78	1.4	6	1.8
	4	8	17.4	16.5	15.9	1460	83	0.85	1.3	6.5	1.8
YD160L	6	9	20.6	19.6	18.9	970	85	0.78	1.4	6	1.8
	4	11	23.4	22.2	21.4	1460	84	0.85	1.3	6.5	1.8
YD180M	6	11	25.9	24.6	23.7	980	85	0.78	1.4	6	1.8
	4	14	29.8	28.3	27.3	1470	85	0.85	1.3	6.5	1.8
YD180L	6	13	29.4	27.9	26.9	980	86	0.78	1.4	6	1.8
	4	16	33.6	31.9	30.8	1470	85	0.85	1.3	6.5	1.8
YD200L	6	18.5	41.4	39.3	37.9	980	87	0.78	1.4	6.5	1.8
	4	22	44.7	42.5	40.9	1460	87	0.86	1.3	7	1.8
YD225	6	22	44.2	42.0	40.5	980	88	0.86	1.4	6.5	1.8
	4	28	56.2	53.4	51.5	1470	87	0.87	1.3	7	1.8
YD225M	6	26	52.2	49.6	47.8	980	88	0.86	1.4	6.5	1.8
	4	34	66	62.7	60.4	1470	87	0.9	1.3	7	1.8
YD250M	6	32	62.1	59.0	56.9	980	90	0.87	1.4	6.5	1.8
	4	42	74.7	71.0	68.4	1470	88	0.91	1.3	7	1.8
YD280S	6	42	81.5	77.4	74.6	980	90	0.87	1.4	6.5	1.8
	4	55	104.2	99.0	95.4	1470	89	0.9	1.3	7	1.8
YD280M	6	55	106.7	101.4	97.7	990	90	0.87	1.4	6.5	1.8
	4	72	138.1	131.2	126.5	1480	89	0.89	1.3	7	1.8
4/8极Pole											
YD90L	8	0.45	1.9	1.8	1.7	680	58	0.63	1.5	5.5	1.8
	4	0.75	1.92	1.8	1.8	1420	72	0.87	1.5	6.5	1.8
YD100L	8	0.85	3.1	2.9	2.8	700	68	0.63	1.5	5.5	1.8
	4	1.5	3.5	3.3	3.2	1420	75	0.88	1.5	6.5	1.8
YD112M	8	1.5	5	4.8	4.6	700	72	0.63	1.5	5.5	1.8
	4	2.4	5.3	5.0	4.9	1420	78	0.88	1.5	6.5	1.8
YD132S	8	2.2	7	6.7	6.4	720	75	0.64	1.5	5.5	1.8
	4	3.3	7.1	6.7	6.5	1450	80	0.88	1.5	6.5	1.8
YD132M	8	3	9	8.6	8.2	720	78	0.65	1.5	5.5	1.8
	4	4.5	9.4	8.9	8.6	1440	82	0.88	1.5	6.5	1.8
YD160M	8	5	13.9	13.2	12.7	730	83	0.66	1.5	5.5	1.8
	4	7.5	15.2	14.4	13.9	1450	84	0.89	1.5	6.5	1.8

YD系列技术参数 Technical data

电机型号 Type	极数 Poles	输出功率 Output KW	额定电流 Rated current (A)			转速 Speed RPM	效率 Efficiency %	功率因数 Power factor Cos Φ	堵转转矩 额定转矩 Ts/Tn	堵转电流 额定电流 Is/In	最大转矩 额定转矩 Tmax/Tn
			380V	400V	415V						
4/8极Pole											
YD160L	8	7	19	18.1	17.4	730	85	0.66	1.5	5.5	1.8
	4	11	21.8	20.7	20.0	1450	86	0.89	1.5	6.5	1.8
YD180L	8	11	26	24.7	23.8	730	86	0.74	1.5	6	1.8
	4	17	31.9	30.3	29.2	1470	87	0.92	1.5	7	1.8
YD200LA	8	14	33	31.4	30.2	740	86	0.74	1.5	6	1.8
	4	22	41.3	39.2	37.8	1470	88	0.92	1.5	7	1.8
YD200LB	8	17	40.1	38.1	36.7	740	87	0.74	1.5	6	1.8
	4	26	48.8	46.4	44.7	1470	88	0.92	1.5	7	1.8
YD225M	8	24	53.2	50.5	48.7	740	89	0.77	1.4	6	1.8
	4	34	66.7	63.4	61.1	1470	88	0.88	1.3	7	1.8
YD250M	8	30	64.9	61.7	59.4	740	90	0.78	1.4	6	1.8
	4	42	78.8	74.9	72.2	1480	89	0.91	1.3	7	1.8
YD280S	8	40	83.5	79.3	76.5	740	91	0.8	1.4	6	1.8
	4	55	102	96.9	93.4	1480	90	0.91	1.3	7	1.8
YD280M	8	47	96.9	92.1	88.7	740	91	0.81	1.4	6	1.8
	4	67	122.9	116.8	112.5	1480	90	0.92	1.3	7	1.8
6/8极Pole											
YD90S	8	0.35	1.6	1.5	1.5	680	56	0.6	1.5	5	1.8
	6	0.45	1.4	1.3	1.3	930	70	0.72	1.5	6	1.8
YD90L	8	0.45	1.9	1.8	1.7	680	59	0.6	1.5	5	1.8
	6	0.65	1.9	1.8	1.7	930	71	0.73	1.5	6	1.8
YD100L	8	0.72	2.9	2.8	2.7	710	65	0.6	1.5	5	1.8
	6	1.1	3.1	2.9	2.8	950	75	0.73	1.5	6	1.8
YD112M	8	1.3	4.5	4.3	4.1	710	72	0.61	1.5	5	1.8
	6	1.8	4.8	4.6	4.4	950	78	0.73	1.5	6	1.8
YD132S	8	1.8	5.8	5.5	5.3	730	72	0.62	1.5	5	1.8
	6	2.4	6.2	5.9	5.7	970	80	0.73	1.5	6	1.8
YD132M	8	2.6	8.2	7.8	7.5	730	78	0.62	1.5	5	1.8
	6	3.7	9.4	8.9	8.6	970	82	0.73	1.5	6	1.8
YD160M	8	4.5	13.3	12.6	12.2	730	83	0.62	1.5	5	1.8
	6	6	14.7	14.0	13.5	980	85	0.73	1.5	6	1.8
YD160L	8	6	17.5	16.6	16.0	730	84	0.62	1.5	5	1.8
	6	8	19.4	18.4	17.8	980	86	0.73	1.5	6	1.8
YD180M	8	7.5	21.9	20.8	20.1	730	84	0.62	1.5	5	1.8
	6	10	24.2	23.0	22.2	980	86	0.73	1.5	6	1.8
YD180L	8	9	24.8	23.6	22.7	930	85	0.65	1.5	5	1.8
	6	12	28.3	26.9	25.9	980	86	0.75	1.5	6	1.8
YD200LA	8	12	32.5	30.9	29.8	730	86	0.65	1.5	5	1.8
	6	17	39.1	37.1	35.8	980	87	0.76	1.5	6	1.8
YD200LB	8	15	40.3	38.3	36.9	730	87	0.65	1.5	5	1.8
	6	20	45.4	43.1	41.6	980	88	0.76	1.5	6	1.8

## YL、YC、YY系列铝壳单相异步电动机 YL, YC, YY series Aluminium Single Phase Motor

YL、YC、YY系列铝壳单相异步电动机，符合国际电工协会IEC有关规定，选用优质材料，进行最新式整体设计。具有性能好、噪声低、振动小、运行安全可靠、外形美观、体积小、重量轻、结构简单、维修方便等优点。

本系列电动机适用于空气压缩机、泵、风机、医疗器械及小型机械等。

YL, YC, YY series aluminium single phase motor, with latest design in entirety, are made of selected quality materials and conform to the IEC standard. YL, YC, YY motors have good performance, safety and reliable operation, nice appearance, and can be maintained very conveniently, while with low noise, little vibration, light weight and simple construction.

These series motors can be used for air-compressor, pump, fan, medical apparatus and instruments, and many other small machines.

### 使用条件

环境空气温度:  $-15^{\circ}\text{C} \leq \theta \leq 40^{\circ}\text{C}$   
 海拔: 不超过1000m  
 电压: 110V、115V、120V、220V、240V  
 频率: 50Hz、60Hz  
 工作制: S1  
 绝缘等级: B、F  
 防护等级: IP44、IP54、IP55  
 冷却方式: IC 411

### Operating Conditions

Ambient temperature:  $-15^{\circ}\text{C} \leq \theta \leq 40^{\circ}\text{C}$   
 Altitude: Not exceed 1000m  
 Rated voltage: 110V, 115V, 120V, 220V, 240V  
 Rated frequency: 50Hz, 60Hz  
 Duty: S1  
 Insulation class: B, F  
 Protection class: IP44, IP54, IP55  
 Cooling method: IC 411



## YL、YC、YY系列铝壳单相异步电动机安装及外形尺寸 YL YC YY series aluminium single phase motor instruction and overall dimension

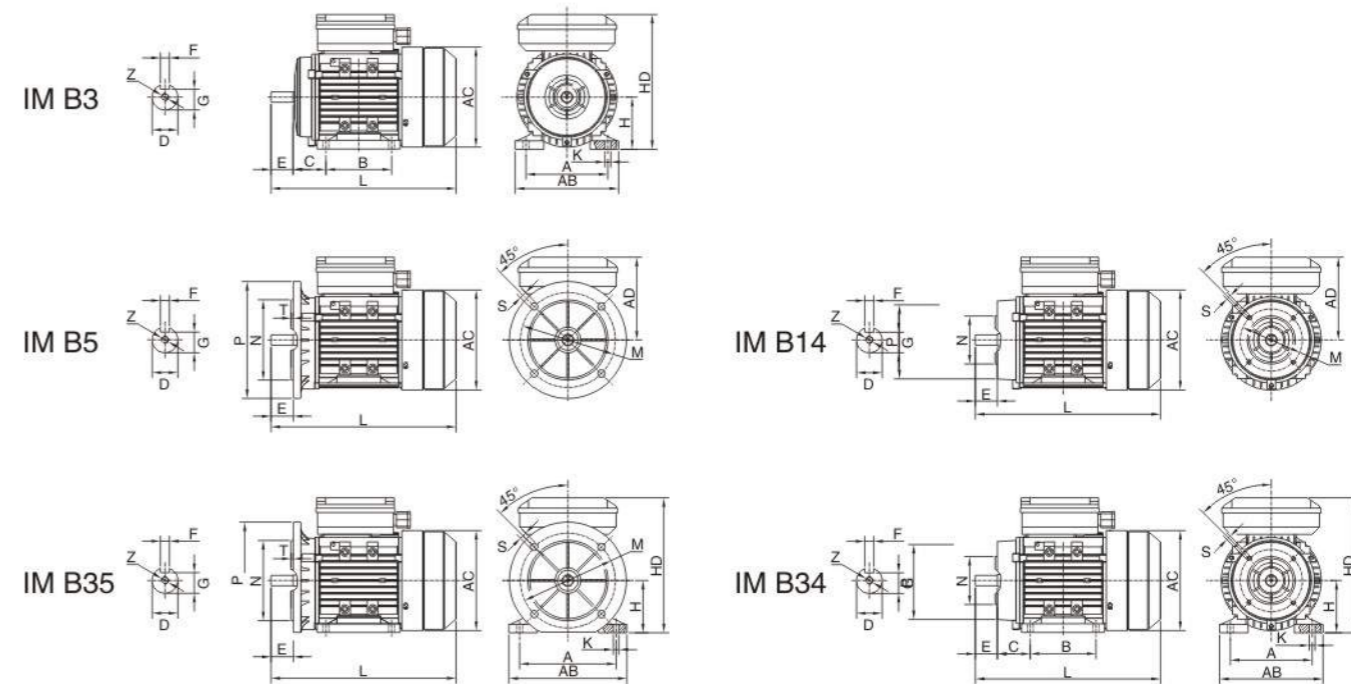

机座号 Frame No.	安装尺寸 Mounting Dimensions										B14、B34					B5、B35					外形尺寸 Overall Dimensions				
	A	B	C	D	E	F	G	H	K	Z	P	M	N	S	T	P	M	N	S	T	AB	AC	AD	HD	L
71	112	90	45	14	30	5	11	71	7	M5×12	105	85	70	M6	2.5	160	130	110	9	3.5	140	135	115	185	255
80M	125	100	50	19	40	6	15.5	80	10	M6×16	120	100	80	M6	3	200	165	130	12	3.5	158	155	125	205	290
90S	140	100	56	24	50	8	20	90	10	M8×19	140	115	95	M8	3	200	165	130	12	3.5	175	175	135	225	315
90L	140	125	56	24	50	8	20	90	10	M8×19	140	115	95	M8	3	200	165	130	12	3.5	175	175	135	225	340
100L	160	140	63	28	60	8	24	100	12	M10×22	160	130	110	M8	3.5	250	215	180	15	4	200	195	145	245	370
112M	190	140	70	28	60	8	24	112	12	M10×22	160	130	110	M8	3.5	250	215	180	15	4	225	220	165	277	395

## YL系列单相双值电容异步电动机技术数据 Single phase double capacitors asynchronous motors

电机型号 Type	功率 Output W	转速 Speed r/min	电流 (A) Current			效率 Efficiency η %	功率因素 Power factor COS φ	堵转转矩 额定转矩 Ts/Tn	最大转矩 额定转矩 Tmax/Tn
			220V	230V	240V				
YL7112	0.37	2800	2.7	2.6	2.5	67	0.92	1.8	1.7
YL7122	0.55	2800	3.9	3.7	3.6	70	0.92	1.8	1.7
YL7114	0.25	1400	2.0	1.9	1.8	62	0.92	1.8	1.7
YL7124	0.37	1400	2.8	2.7	2.6	65	0.92	1.8	1.7
YL8012	0.75	2800	5.1	4.9	4.7	72	0.92	1.8	1.7
YL8022	1.1	2800	7.0	6.7	6.4	75	0.95	1.8	1.7
YL8014	0.55	1400	3.9	3.8	3.6	69	0.92	1.7	1.7
YL8024	0.75	1400	5.1	4.8	4.6	71	0.95	1.7	1.7
YL90S-2	1.5	2800	9.2	8.8	8.4	76	0.98	1.8	1.7
YL90L-2	2.2	2800	13.3	12.7	12.1	77	0.98	1.7	1.7
YL90S-4	1.1	1400	7.2	6.9	6.6	73	0.95	1.7	1.7
YL90L-4	1.5	1400	9.6	9.2	8.8	75	0.95	1.7	1.7
YL100L-2	3	2800	18.2	17.4	16.7	79	0.95	1.7	1.7
YL100L1-4	2.2	1400	13.9	13.2	12.7	76	0.95	1.7	1.7
YL100L2-4	3	1400	18.6	17.8	17.1	77	0.95	1.7	1.7
YL112M-2	3.7	2800	22.1	21.2	20.3	80	0.95	1.7	1.7
YL112M-4	3.7	1400	22.4	21.4	20.5	79	0.95	1.7	1.7

YY单相电容运转电机技术数据 Single phase running capacitor motor technical data

电机型号 Type	功率 Outout W	转速 Speed r/min	电流 (A) Current			效率 Efficiency η%	功率因素 Powerfactor COS φ	堵转转距 额定转矩 Ts/Tn	最大转矩 额定转矩 Tmax/Tn
			220V	230V	240V				
YY5612	90	2800	0.8	0.8	0.7	56	0.92	0.5	1.7
YY5622	120	2800	1.0	0.9	0.9	60	0.92	0.5	1.7
YY6312	180	2800	1.4	1.3	1.3	65	0.92	0.4	1.7
YY6322	250	2800	1.9	1.8	1.7	66	0.92	0.4	1.7
YY7112	370	2800	2.7	2.6	2.5	67	0.92	0.35	1.7
YY7122	550	2800	3.9	3.7	3.6	70	0.92	0.35	1.7
YY8012	750	2800	5.1	4.9	4.7	72	0.92	0.33	1.7
YY8022	1100	2800	7.0	6.7	6.4	75	0.95	0.33	1.7
YY90S2	1500	2800	9.4	9.0	8.7	76	0.95	0.3	1.7
YY90L2	2200	2800	12.7	13.1	12.5	77	0.95	0.3	1.7
YY5614	60	1400	0.6	0.6	0.6	50	0.9	0.45	1.7
YY5624	90	1400	0.9	0.8	0.8	52	0.9	0.45	1.7
YY6314	120	1400	1.1	1.0	1.0	57	0.9	0.4	1.7
YY6324	180	1400	1.5	1.5	1.4	59	0.9	0.4	1.7
YY7114	250	1400	2.0	1.9	1.9	61	0.92	0.35	1.7
YY7124	370	1400	2.9	2.8	2.7	62	0.92	0.35	1.7
YY8014	550	1400	4.2	4.1	3.9	64	0.92	0.35	1.7
YY8024	750	1400	5.4	5.2	5.0	68	0.92	0.32	1.7
YY90S4	1100	1400	7.4	7.1	6.8	71	0.95	0.32	1.7
YY90L4	1500	1400	9.8	9.4	9.0	73	0.95	0.3	1.7

YC单相电容启动电机技术数据 Single phase starting capacitor motor technical data

电机型号 Type	功率 Outout W	转速 Speed r/min	电流 (A) Current			效率 Efficiency η%	功率因素 Powerfactor COS φ	堵转转距 额定转矩 Ts/Tn	最大转矩 额定转矩 Tmax/Tn
			220V	230V	240V				
YC7112	180	2800	1.9	1.8	1.7	60	0.72	3	1.8
YC7122	250	2800	2.4	2.3	2.2	64	0.74	3	1.8
YC8012	370	2800	3.4	3.2	3.1	65	0.77	2.8	1.8
YC8022	550	2800	4.7	4.5	4.3	68	0.79	2.8	1.8
YC90S2	750	2800	6.1	5.8	5.6	70	0.8	2.5	1.8
YC90L2	1100	2800	8.7	8.3	8.0	72	0.8	2.5	1.8
YC100L1-2	1500	2800	11.4	10.9	10.4	74	0.81	2.5	1.8
YC100L2-2	2200	2800	16.5	15.7	15.1	75	0.81	2.2	1.8
YC112M2	3000	2800	21.9	20.9	20.1	76	0.82	2.2	1.8
YC7114	120	1400	1.9	1.8	1.7	50	0.58	3	1.8
YC7124	180	1400	2.5	2.4	2.3	53	0.62	2.8	1.8
YC8014	250	1400	3.1	3.0	2.9	58	0.63	2.8	1.8
YC8024	370	1400	4.2	4.1	3.9	62	0.64	2.5	1.8
YC90S4	550	1400	5.5	5.3	5.0	66	0.69	2.5	1.8
YC90L4	750	1400	6.9	6.6	6.3	68	0.73	2.5	1.8
YC100L1-4	1100	1400	9.5	9.1	8.7	71	0.74	2.5	1.8
YC100L2-4	1500	1400	12.5	11.9	11.4	73	0.75	2.5	1.8
YC112M4	2200	1400	17.8	17.0	16.3	74	0.76	2.2	1.8

其它产品  
Other Products



快速门控制系统

快速门控制系统



快速门专用电机

快速门专用电机



喷灌机专用电机



YAEJ电机